

KOBELCO

SK650DLC-11

Performance  Design

Ultra High Reach Demolition Machine

SK650D_{LC}



Complies with the EU Stage V
exhaust emission regulation

Built for Perfectionists

Performance X Design

PERFORMANCE — Constant pursuit of efficiency and productivity with more power, more speed.

DESIGN — Operator-centric with an uncompromising stance on good ease-of-use and comfort.

We've melded these principles to create the new 60ton class building demolition machine SK650DLC, the embodiment of all-new values.

Not just improved performance and design, this new dedicated machine sports new functionality and mechanism.

Once you experience this one-of-a-kind you will never forget, and that KOBELCO continues to push the bar higher.

SK650DLC



To the Next Level of Power and Functional Aesthetics

High-torque engine, compliant with the latest regulations

The new SK650DLC is equipped with a Stage V compliant engine, which has a higher torque value. Superior balance between engine output and torque contributes to more efficient performance than the previous models.

Model : ISUZU 6WG1

Engine output

348 kW/1,800 min⁻¹

(ISO 14396)



Hydraulic drive cooling fan

Hydraulic drive optimises the cooling fan rotation speed to improve fuel economy and reduce noise. Also, the independent oil cooler fan better matches cooling to the hydraulic oil temperature, for optimal oil temperature control.



Reversible fan

With the flip of a switch from the driver's seat, the standard feature reversing fan pulls air in the opposite direction, blowing debris away to prevent clogging. This also renders burdensome and time consuming daily cleaning unnecessary.



Air suspension seat

GRAMMER* air suspension seat with heat is standard. It has superior shock absorption and can be used for long periods of time and reducing fatigue.



In addition to the standard headrest, a large neck rest compatible with hard hats is also included.

* GRAMMER is trademark of GRAMMER AG, registered in Germany and other countries.

Large 10-inch colour monitor

Incorporates the industry's biggest large-format monitor. The information you need is easy to see and operating the menus is simple.

The large camera image means you can quickly confirm safety conditions.



Cab Features That Enhance Every Working Hour

Equipped with a smartphone holder, LED lighting, USB port, and a 12 V outlet to enhance comfort and usability during every operation.



Smartphone holder



Advanced LED backlight



Automatic LED door light



USB port /12V power outlet

Specification selection

Select attachments to perform demolition from high heights to lower stories, and even basement levels with just one machine.

Ultra long attachment specification

Excels at demolishing aging five to eight story buildings

Uses a 3-piece ultra long attachment with cross-cylinder construction. By combining one type of arm and an optional boom insert, you can choose from a total of two attachment configurations to reach the heights you need. Ideal for demolition sites that require a height of 25.3 m to 28.2 m or less.

Maximum working height (arm top pin)

8.2 m arm, with boom insert : **Approximately 28.2 m**

8.2 m arm, without boom insert : **Approximately 25.3 m**

Max.tool weight

with / without boom insert : **3,700 kg**

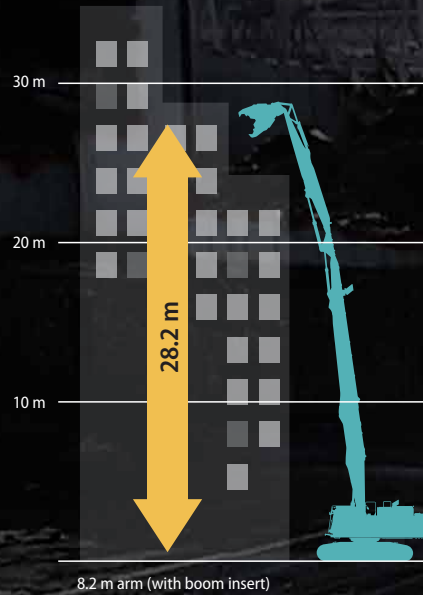

*Attachment Tool Not Included

Separate boom specification (with / without boom insert)

Demolition specifications for diverse tasks

The Separate Boom specification offers a wide working range, enabling demolition of low-rise and ground-level foundations. The powerful attachment support provided by the large-diameter jib cylinder allows for efficient work at tall heights. Furthermore, by attaching the boom insert, it became possible to demolish buildings up to 18.2 m tall.



*Attachment Tool Not Included

Max.tool weight

with / without boom insert : **6,100 kg**

■ Without boom insert

■ With boom insert

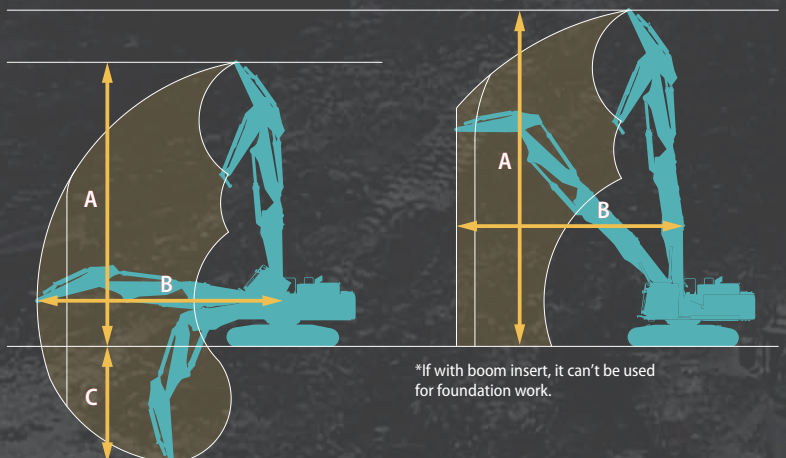

	Without boom insert	With boom insert
A - Max. operation height	m 15.3	18.2
B - Max. operation reach	m 13.2	12.3
C - Max. operation depth	m 6.3	

Assembly / Disassembly

Incorporate KOBELCO's state-of-the-art technology.

Quick assembly NEXT joint system

KOBELCO's original NEXT joint system was developed through extensive testing of the assembly and disassembly processes. The boom attachment can be connected simply by hooking the upper pin and securing it with the left-right separated hydraulic pin on the lower side. In addition, a newly designed storage stand integrated with the work platform makes assembly and disassembly safer and easier.

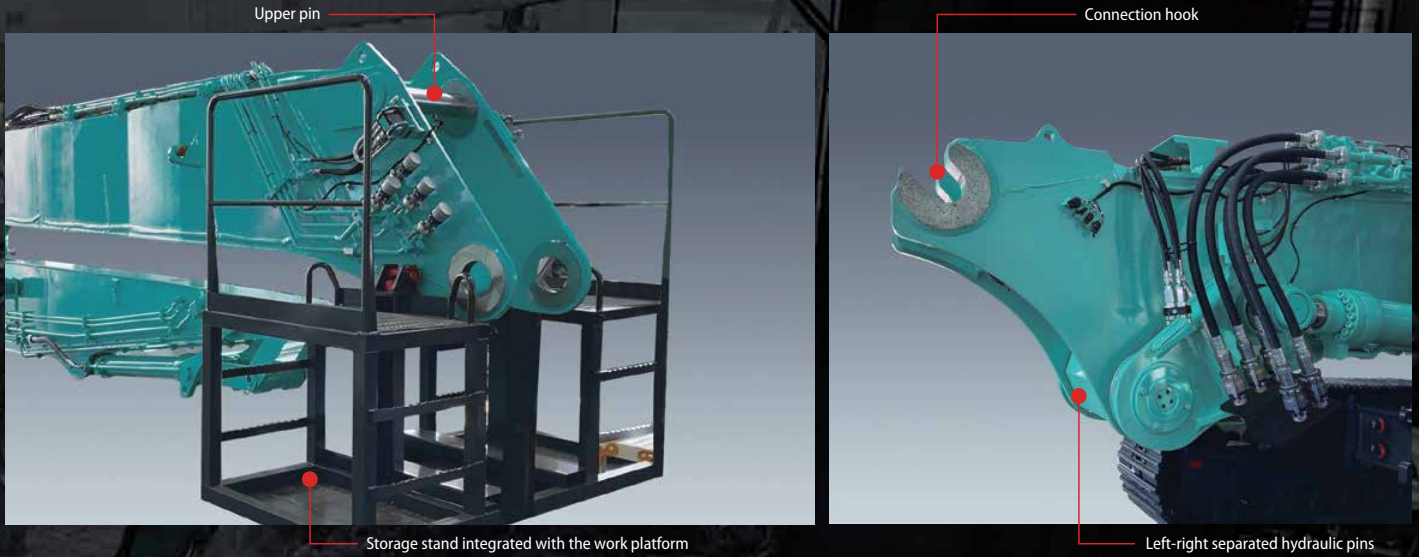

Piping connection also simple with multi-coupler and quick-coupler

The hydraulic piping at the attachment mounting joint part uses multi-couplers or quick couplers, allowing for easy connection and disconnection without the use of tools.

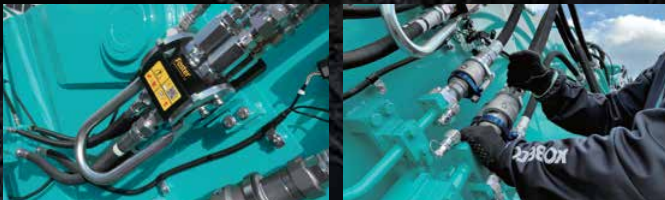

Bucket link with lifting hook is equipped as standard

Lifting hook equipped on the bucket link part with the separate boom specification. It can lift the ultra long attachment by itself, so no loading crane is necessary when changing attachments or loading/unloading the machine onto a transport truck.



Transport the machine

Minimize overall height, width and weight for easy and safe transportation

Lower overall height of attachment during transportation

[NEXT Ultra long attachment specification]

The cross-cylinder layout keeps the overall height low when folded, so it can be transported on a standard trailer without worrying about height restrictions.

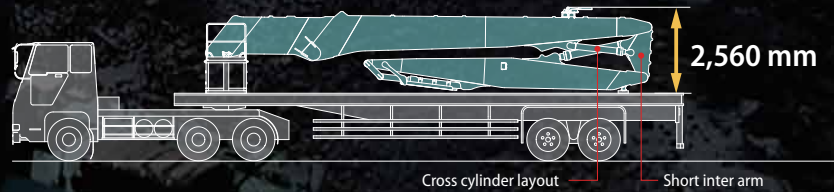

Removable inner part of counterweight

The counterweight consists of a case and a removable inner part, which can be easily removed to reduce the overall weight when transporting the base machine.

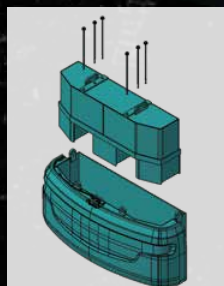

Variable Gauge Crawler (Hydraulic)

A crawler extension/retraction mechanism is provided for retracting the lower width for trailer loading. Extension / retraction can be performed easily with the hydraulic mechanism while the machine is grounded with the shoes. No need to fasten any bolts.

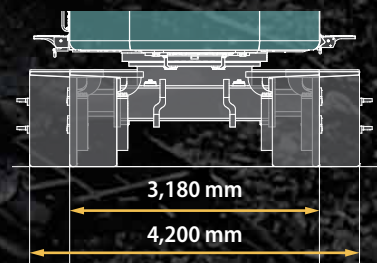

*for 600 mm shoe

Reliability and safety

KOBELCO's latest technology for keeping the machine in top shape and protecting the operator.

Stability warning system with longitudinal/horizontal detection

The device calculates the tipping danger area from the posture of the attachment and swing angle of upper structure, and if it detects a dangerous situation, it alerts the operator with an alarm and a warning on the screen. System distinguishes between the front and sides by detecting the position relative to the upper structure and crawler. As the system recognises that the safe working range differs between the front and sides, the upper structure can swing within a wider restricted range for each.



Stability warning display

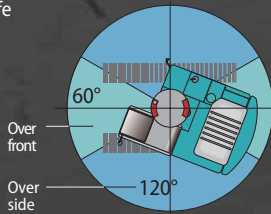

Displaying the machine's posture assists in demolition work

The monitor displays the longitudinal and lateral tilt of the base machine. The operator can also check the working radius and height on the monitor, enabling accurate understanding of the working status of the machine.

CUSTOM NIBBLER(1)		
3P HIGH REACH		
RADIUS	4.5m	
HEIGHT	5.6m	Working height
BOOM ANGLE	92°	
+ ()	0.0°	Base machine tilt
- ()	0.0°	

LED work light to keep visibility in low light or at night

Equipped with eight high brightness LED work lights. The lights keep the work area bright even in low light or at night. Work area safety can also be quickly confirmed.



Upper structure (1 light)



Cab top (2 lights)



Cab bottom (1 light)



Attachment (2 lights)

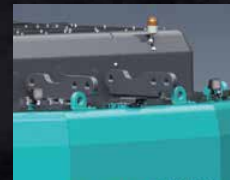

Counterweight (2 lights)

Cab interference prevention system with soft-stop feature

If the attachment comes within a certain distance of the cab, an alarm and warning on the screen alert the operator, and the attachment stops softly and automatically to protect the operator. Since there is no worry of contact, the operator can confidently perform lever operation even close to the cab.



Boom angle sensor



Jib angle sensor



Arm angle sensor



Bucket angle sensor



Cab interference warning display

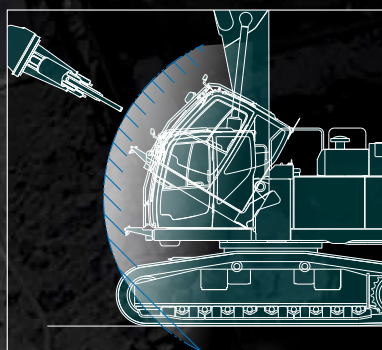

Right, left and rear view cameras / Eagle-Eye View

Cameras are equipped on the rear, right, and left sides of the base machine. Camera image is easily visible on the large 10-inch monitor. The blind spots behind and to the right can be checked in a glance from the operator's seat to confirm safety. The operator can choose how to display the camera image.



Simultaneous rear/right view

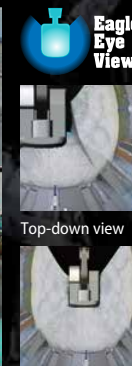

Eagle-eye view

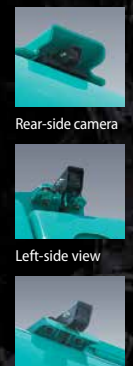

Right-side camera

*Attachment Tool Not Included

Protection and comfortably

A unique operating environment of building demolition machine to prevent operator fatigue.

Demolition spec cab with tilting function

A Demolition spec cab with a 30° tilt capability is equipped as standard for comfortably demolishing tall buildings where the operator spends a long time looking up. With no beam between the front window and skylight to block visibility and angled grids on the cab guard, good work visibility is maintained. In addition, the large front wiper ensures thorough wiping all the way down to the footwell area.



Excellent visibility (Front and Skylight)



Front guard and Top guard are standard



Cab can be tilted up to 30 degrees

Equipment

Multiple standard features and accessories built for demolition and ensuring safety.



Upper frame and Lower frame guard

The components inside the base machine are protected by 6mm and 9mm thick steel plate covers.



Foldable walkway

Walkways are installed on both the left and right sides at the base of the machine, providing easier access for maintenance.



Safety valve for boom & arm jib cylinder

Prevents attachment from falling if piping is ruptured.



Bucket cylinder guard

Prevents damage to the cylinder from falling debris.



Full track guide

Prevents treads from coming off when mounting on demolition rubble.



Public address system

Alert workers in the area with clear audio quality.



Cab lower mirror

Check safety at foot areas and under the cab when tilted.



Cab entry step

Positioned for convenient access to the tilt cab.



Auto lubrication system

Quickly lubricate the attachments.



Water spray

It helps to prevent the spread of dust generated during demolition.



Falling object deflector

The guard deflects falling debris away from the machine. This is standard for the ultra long attachment.



Chain scrubber

The chain scrubber removes debris wrapped around the shoes and protects the upper frame from damage.

* The accessory settings may differ according to the specification. Refer to the list of key accessories on the back page for details.

Specifications



Engine

Model	ISUZU 6WG1
Type	Four-cycle, water-cooled, direct injection diesel engine, turbo charged, EU Stage V exhaust emission regulation
No. of cylinders	6
Bore and stroke	147 mm × 154 mm
Displacement	15.681 L
Rated power output	348 kW / 1,800 min ⁻¹ (ISO 14396: without fan)
Max. torque	2,050 N·m / 1,300 min ⁻¹ (ISO 14396: without fan)



Hydraulic system

Pump	
Type	Two variable displacement piston pumps + rotary pump + pilot pump
Max. discharge flow	2 × 370 L/min, 1 × 58.5 L/min, 1 × 27 L/min
Relief valve setting	
Boom, arm and bucket	34.3 MPa
Power Boost	37.8 MPa
Travel circuit	34.3 MPa
Swing circuit	26.0 MPa
Control circuit	5.0 MPa
Nibbler (Crusher) circuit	Open & Close 24.5 MPa (Up to 37.8 MPa) Rotation 20.6 MPa
Pilot control pump	Gear type
Main control valves	8 + 2-spool
Oil cooler	Air cooled type



Swing system

Swing motor	Two fixed displacement piston motor
Brake	Hydraulic; locking automatically when the swing control lever is in the neutral position
Parking brake	Wet multiple plate
Swing speed	4.0 min ⁻¹ (Ultra long attachment) 6.4 min ⁻¹ (Separate boom)
Swing torque	188 kN·m



Travel System

Travel motors	2 × axial-piston, two-step motors
Travel brakes	Hydraulic brake per motor
Parking brakes	Oil disc brake per motor
Travel shoes	55 each side
Travel speed (high / low)	5.3/2.7 km/h
Drawbar pulling force (with / without boom insert) (SAE J 1309)	472 kN / 473 kN (Separate boom) 473 kN / 474 kN (Ultra long attachment)



Cab & control

Cab	
All-weather, sound-suppressed steel cab mounted on the silicon-sealed viscous mounts and equipped with a heavy, insulated floor mat Demolition spec cab with tilting function (30°)	
Control	
Two hand levers and two foot pedals for travel	
Two hand levers and one foot pedal for front attachment and swing	
Electric rotary-type engine throttle	
Noise levels	
External	106 dB(A) (2000/14/EC)
Operator	72 dB(A) (ISO 6396)
Vibration levels	
Hand/arm*	≤ 2.5 m/s ²
Body*	≤ 0.5 m/s ²

* For the risk assessment according to 2002/44/EC, refer to ISO/TR 25398: 2006.



Cylinders

bore x stroke (mm)

Attachment type	NEXT Ultra long attachment
Boom cylinders	190 × 1,630
Jib cylinders	150 × 1,231
Arm cylinder	180 × 1,404
Bucket cylinder	150 × 1,193
Attachment type	Separate attachment
Boom cylinders	190 × 1,630
Jib cylinders	270 × 1,418
Arm cylinder	190 × 1,990
Bucket cylinder	160 × 1,410



Refilling capacities & lubrications

Fuel tank	720 L
Cooling system	69 L
Engine oil	57 L
Travel reduction gear	2 × 18 L
Swing reduction gear	2 × 5 L
Hydraulic oil tank	370 L tank oil level 803 L hydraulic system
DEF/Urea tank	83 L

Operating Weight & Ground Pressure

Attachment Type	NEXT Ultra long attachment / equipment*		Separate boom attachment*	
	8.2 m arm with boom insert (28.2 m height)	8.2 m arm without boom insert (25.3 m height)	with boom insert (18.2 m height)	without boom insert (15.3 m height)
Operating Weight	79,000 kg	76,200 kg	80,700 kg	77,900 kg
Ground Pressure	120 kPa	116 kPa	123 kPa	118 kPa

* Measured with max tool weight

Specifications



Working Ranges

Working ranges with max tool weight installed. Although within Max. tool weight, depending on the tool type and working position of the front attachment, the cylinder may not hold the excessive load making it difficult to perform the intended work.

Unit: mm

NEXT Ultra long attachment specification: 8.2 m arm + 3.0 m boom insert

Max. tool weight = 3,700 kg
Arm top pin diameter = ø90 mm

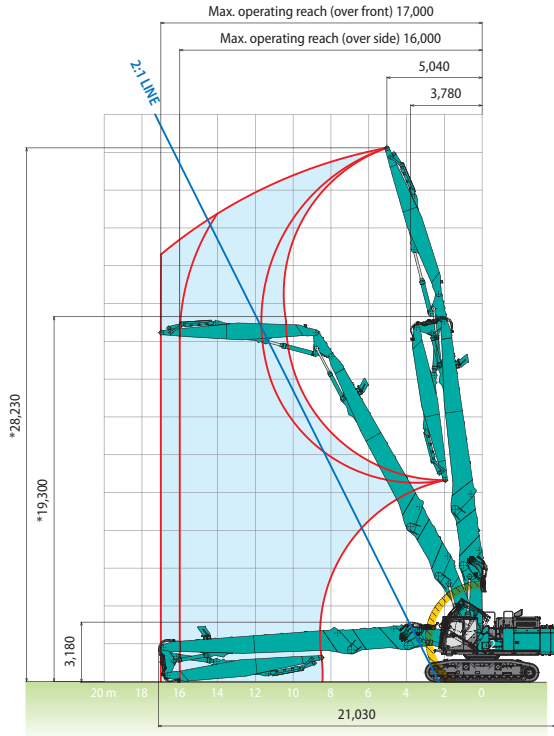

NEXT Ultra long attachment specification: 8.2 m arm

Max. tool weight = 3,700 kg
Arm top pin diameter = ø90 mm

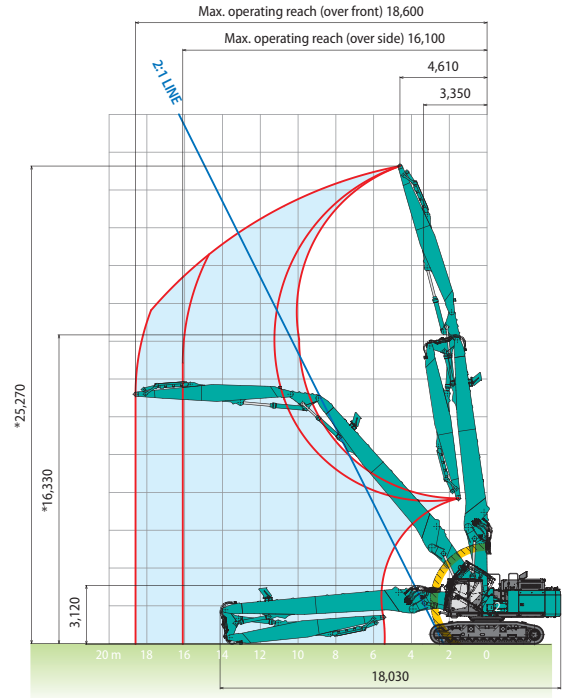

NEXT Separate boom specification: 3.45 m arm + 3.0 m boom insert

Max. tool weight = 6,100 kg
Arm top pin diameter = ø110 mm

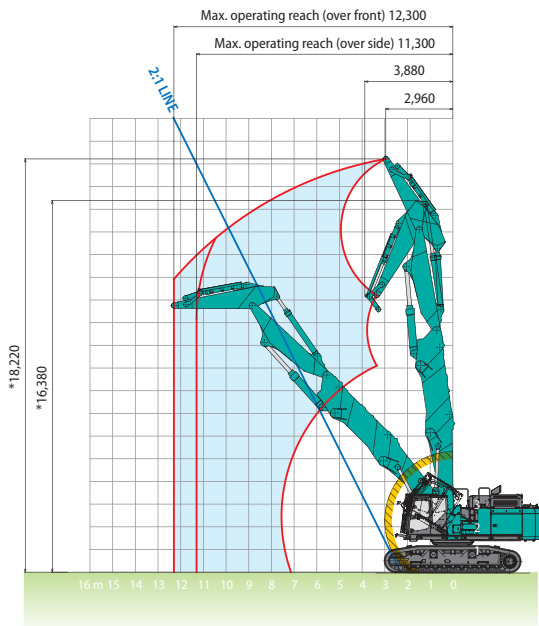

NEXT Separate boom specification: 3.45 m arm

Max. tool weight = 6,100 kg
Arm top pin diameter = ø110 mm

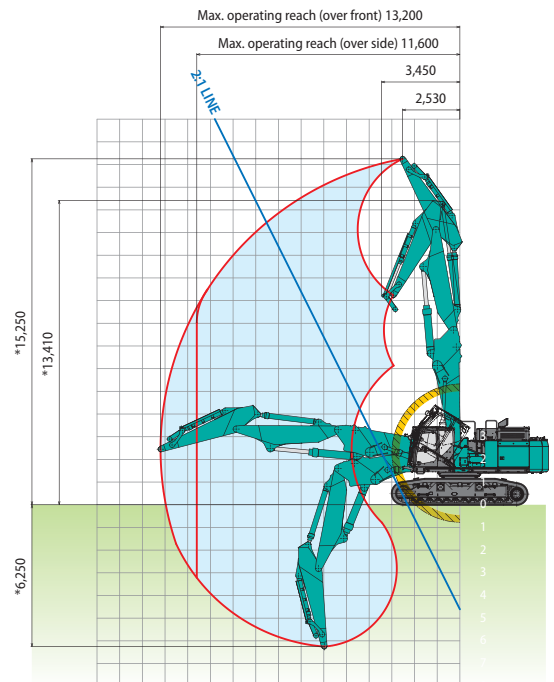

*Without including height of shoe lug.

**Cab interference prevention system operating area.

***Max tool weight, operation height, and working range provided in this brochure are based on the arm top pin.

Lift capacities

SK650D^{LC}

SK650DLC-11

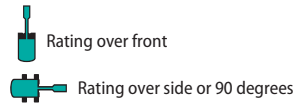
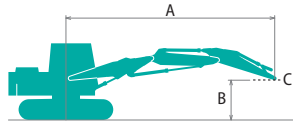

A – Reach from swing centerline to arm top
 B – Arm pin height above/below ground
 C – Lift point
 Relief valve setting: 37.8 MPa

SK650DLC		Separate boom	Without boom insert	Arm: 3.45 m		Without front attachment		Counterweight: 15,200 kg		Shoe: 600 mm (Heavy Lift)								
B	A	3.0 m		4.5 m		6.0 m		7.5 m		9.0 m		10.5 m		12.0 m		At max. reach		Radius
15.0 m	kg	*23,410	*23,410													*21,590	*21,590	3.63 m
13.5 m	kg			*17,710	*17,710	*13,590	*13,590									*14,570	*14,570	7.06 m
12.0 m	kg					*15,750	*15,750	*11,450	*11,450	*12,340	*12,340					*12,390	*12,390	9.03 m
10.5 m	kg			*13,050	*13,050	*14,640	*14,640	*15,760	*15,760	*10,590	*10,590					*11,290	*11,290	10.41 m
9.0 m	kg			*13,950	*13,950	*15,630	*15,630	*16,560	*16,560	*10,190	*10,190	*10,280	*10,280			*10,670	10,620	11.43 m
7.5 m	kg			*27,540	*27,540	*22,860	*22,860	*18,430	*18,430	*12,220	*12,220	*10,210	*10,210	*10,240	9,720	*10,330	9,440	12.18 m
6.0 m	kg			*27,780	*27,780	*16,630	*16,630	*14,200	*14,200	*12,830	*12,830	*10,560	*10,560	*10,250	9,600	*10,190	8,690	12.70 m
4.5 m	kg			*14,670	*14,670	*19,630	*19,630	*15,820	*15,820	*13,730	*13,730	*11,310	*11,310	*10,660	9,390	*10,210	8,240	13.04 m
3.0 m	kg					*14,110	*14,110	*17,490	17,340	*14,730	13,640	*13,090	11,070	*11,340	9,180	*9,790	8,010	13.19 m
1.5 m	kg					*12,230	*12,230	*18,300	16,870	*15,490	13,240	*13,090	10,790	*11,020	9,020	*9,110	7,980	13.16 m
G.L.	kg			*11,570	*11,570	*11,710	*11,710	*16,560	*16,560	*14,420	13,050	*12,240	10,640	*10,130	8,950	*8,290	8,160	12.97 m
-1.5 m	kg			*25,570	*25,570	*25,340	24,910	*14,310	*14,310	*12,800	*12,800	*10,880	10,630	*8,660	*8,660	*7,260	*7,260	12.58 m
-3.0 m	kg	*25,400	*25,400	*31,420	*31,420	*24,500	*24,500	*19,610	17,990	*10,550	*10,550	*8,850	*8,850			*7,700	*7,700	11.76 m
-4.5 m	kg			*28,610	*28,610	*22,640	*22,640	*18,180	*18,180	*13,740	*13,740					*9,140	*9,140	10.35 m
-6.0 m	kg					*19,030	*19,030									*13,930	*13,930	7.44 m

SK650DLC		Separate boom	With boom insert	Arm: 3.45 m		Without front attachment		Counterweight: 15,200 kg		Shoe: 600 mm (Heavy Lift)							
B	A	4.5 m		6.0 m		7.5 m		9.0 m		10.5 m		12.0 m		At max. reach		Radius	Radius
18.0 m	kg													*22,400	4.00 m	*22,400	4.00 m
16.5 m	kg			*17,960	*17,960	*14,560	*14,560							*14,610	7.86 m	*14,610	7.86 m
15.0 m	kg			*15,410	*15,410	*11,440	*11,440	*11,800	*11,800					*11,350	10.13 m	*11,350	10.13 m
13.5 m	kg			*13,930	*13,930	*14,910	*14,910	*10,560	*10,560	*10,140	*10,140			*9,710	11.77 m	*9,810	11.30 m
12.0 m	kg	*12,540	*12,540	*14,290	*14,290	*15,040	*15,040	*10,190	*10,190	*9,700	*9,700	*9,020		*8,910	12.30 m	*9,320	11.30 m
10.5 m	kg	*23,400	*23,400	*18,740	*18,740	*15,300	*15,300	*10,570	*10,570	*9,530	*9,530	*8,800		*8,670	12.30 m	*9,130	11.30 m
9.0 m	kg	*23,000	*23,000	*18,100	*18,100	*12,710	*12,710	*10,880	*10,880	*9,620	*9,620	*8,760		*8,610	12.30 m	*9,120	11.30 m
7.5 m	kg			*16,610	*16,610	*13,560	*13,560	*11,340	*11,340	*9,870	*9,870	*8,840		*8,680	12.30 m	8,870	11.30 m
6.0 m	kg					*14,570	*14,570	*11,880	11,470	*10,180	9,070	*9,000		*8,810	12.30 m	8,230	11.30 m
4.5 m	kg					*11,960	*11,960	*12,400	10,740	*10,480	8,360	*9,070		*8,820	12.30 m	7,650	11.30 m
3.0 m	kg					*11,570	*11,570	*12,330	10,170	*9,940	7,870	*8,730		*8,500	12.30 m	7,220	11.30 m
1.5 m	kg					*11,370	*11,370	*11,670	9,800	*9,170	7,620	*8,220		*8,010	12.30 m	6,950	11.30 m
G.L.	kg					*11,560	*11,560	*10,340	9,650	*8,210	7,550	*7,520		*7,350	12.30 m	6,840	11.30 m
-1.5 m	kg					*10,630	*10,630	*8,090	*8,090	*7,090	*7,090	*6,630		*6,480	12.30 m	6,860	11.30 m
-3.0 m	kg			*13,780	*13,780	*13,470	*13,470	*11,780	10,370	*5,780	*5,780	*5,510		*5,390	12.30 m	*5,710	11.30 m
-4.5 m	kg			*13,070	*13,070	*12,290	*12,290	*10,830	10,500	*9,310	8,490	*7,440		*7,020	12.30 m	7,670	11.30 m
-6.0 m	kg					*10,650	*10,650	*9,400	*9,400	*7,680	*7,680	*5,410		*4,910	12.30 m	*6,500	11.30 m

- Notes:
- Do not attempt to lift or hold any load that is greater than these lift capacities at their specified lift point radius and height. Weight of all accessories must be deducted from the above lift capacities.
 - Lift capacities are based on machine standing on level, firm, and uniform ground. User must make allowance for job conditions such as soft or uneven ground out of level conditions, side loads, sudden stopping of loads, hazardous conditions, experience of personnel, etc.
 - Arm top pin is defined as lift point.
 - The above lift capacities are in compliance with SAE J/ISO 10567. They do not exceed 87 % of hydraulic lift capacity or 75 % of tipping load. Lifting capacities marked with an asterisk (*) are limited by hydraulic capacity rather than tipping load.
 - Operator should be fully acquainted with the operator's and Maintenance Instructions before operating this machine and rules for safe operation of equipment should be adhered to at all times.
 - Lift capacities apply to only machine as originally manufactured and normally equipped by KOBELCO CONSTRUCTION MACHINERY CO., LTD.
 - This table cannot be applied for high reach demolition machines.

Standard and Optional Equipment

SK650D^{LC}

SK650DLC-11

● = Std ○ = Opt — = not available

Category	Description	SK650DLC-11	
		Separate boom Attachment	Ultra long Attachment
ENGINE	ISUZU 6WG1 (EU Stage V compliant)	●	●
	Exhaust DOC DPD SCR	●	●
	Alternator 24 V / 90 A	●	●
	Starter motor 24 V / 7 kW	●	●
	Batteries 2 x 12V (205 Ah)	●	●
	Reversible hydraulic drive cooling fan	●	●
	Auto deceleration function	●	●
HYDRAULIC SYSTEM	Auto idle stop (AIS)	●	●
	3 work modes H, S, Eco	●	●
	Power boost (37.8 MPa)	●	●
	Heavy lift mode	●	—
	Pressure release function	●	●
	Independent travel function	●	●
	Auto warm up system	●	●
	Proportional Hand Control (for Rotation & N&B piping)	●	●
	Hydraulic oil VG32	●	●
	Hydraulic oil VG46	○	○
	Hydraulic oil VG68	○	○
PIPING	Rotation & N&B piping	●	●
	QH piping	●	●
CABIN	Air suspension seat with heating	●	●
	10-inch colour monitor	●	●
	LED door light	●	●
	Air-conditioner	●	●
	DAB+ radio (FM/AM & AUX & USB & Bluetooth* & hands free telephone)	●	●
	Large wiper	●	●
	12 V power outlet	●	●
	Sun screen	●	●
LIGHTS	Large footrest	●	●
	LED work lights : 2 on cab top, 1 on cab bottom, 1 on upper structure	●	●
	LED work lights : 2 on counterweight	●	●
	LED work lights : 2 on boom	●	—
WORKING EQUIPMENT	LED work lights : 2 on arm	—	●
	NEXT water spray (only piping)	●	●
COUNTERWEIGHT	Bucket link with lifting hook	●	—
UNDERCARRIAGE	Layered C/W (TTL 15,200 kg)	●	●
	VLC (Hydraulic variable gauge crawler)	●	●
	600 mm HD steel shoe	●	●
	600 mm HD double grouser shoe	○	○
	800 mm steel shoe	○	○
	Full track guide	●	●
SAFETY	Lower frame guard	●	●
	Engine emergency stop switch	●	●
	Pump emergency mode (KPSS release switch)	●	●
	Emergency accel dial	●	●
	Emergency manual valve for lowering attachment	●	●
	Emergency manual valve for lowering cab	●	●
	Overload alarm	●	—
	Safety valve for boom & arm & jib cylinder	●	●
	Demolition spec cab (PSA glass, Tilting function)	●	●
	OPG Level II top guard (ISO 10262:1998)	●	●
	OPG Level II front guard (ISO 10262:1998)	●	●
	Eagle-eye view camera (Rear, Right, Left)	●	●
	Cab lower mirror	●	●
	Falling object deflector	—	●
	Travel alarm	○	○
	Seatbelt indicator on display	●	●
	Cab interference prevention system	●	●
	Stability warning system	●	●
	Walkway (Left & Right front side)	●	●
	Public address system	●	●
Emergency escape hammer	●	●	
OTHERS	Refueling pump	●	●
	Auto lubrication system	●	●
	Harness for engine room light	●	●
	Bucket cylinder guard	●	●
	RAL colour	○	○
	KOMEXS	●	●

*The air conditioning system on this machine contains fluorinated greenhouse gas HFC-134a (GWP 1430). Quantity of gas 1.1 kg (CO₂ equivalent 1.6 t)
Note: Bluetooth* is a registered trademark of the Bluetooth SIG Inc.

Note: This catalogue may contain attachments and optional equipment that are not available in your area. And it may contain photographs of machines with specifications that differ from those of machines sold in your areas. Please consult your nearest KOBELCO distributor for those items you require.

Specialist equipment is needed to use this machine in demolition work. Before using it please contact your KOBELCO dealer.

Due to our policy of continuous product improvements all designs and specifications are subject to change without advance notice.

Copyright by **KOBELCO CONSTRUCTION MACHINERY CO., LTD.** No part of this catalogue may be reproduced in any manner without notice.

KOBELCO CONSTRUCTION MACHINERY EUROPE B.V.

www.kobelco-europe.com



Enquiries To: