

KOBELCO

SK550DLC-11

Performance  Design

Ultra High Reach Demolition Excavator

SK550D_{LC}

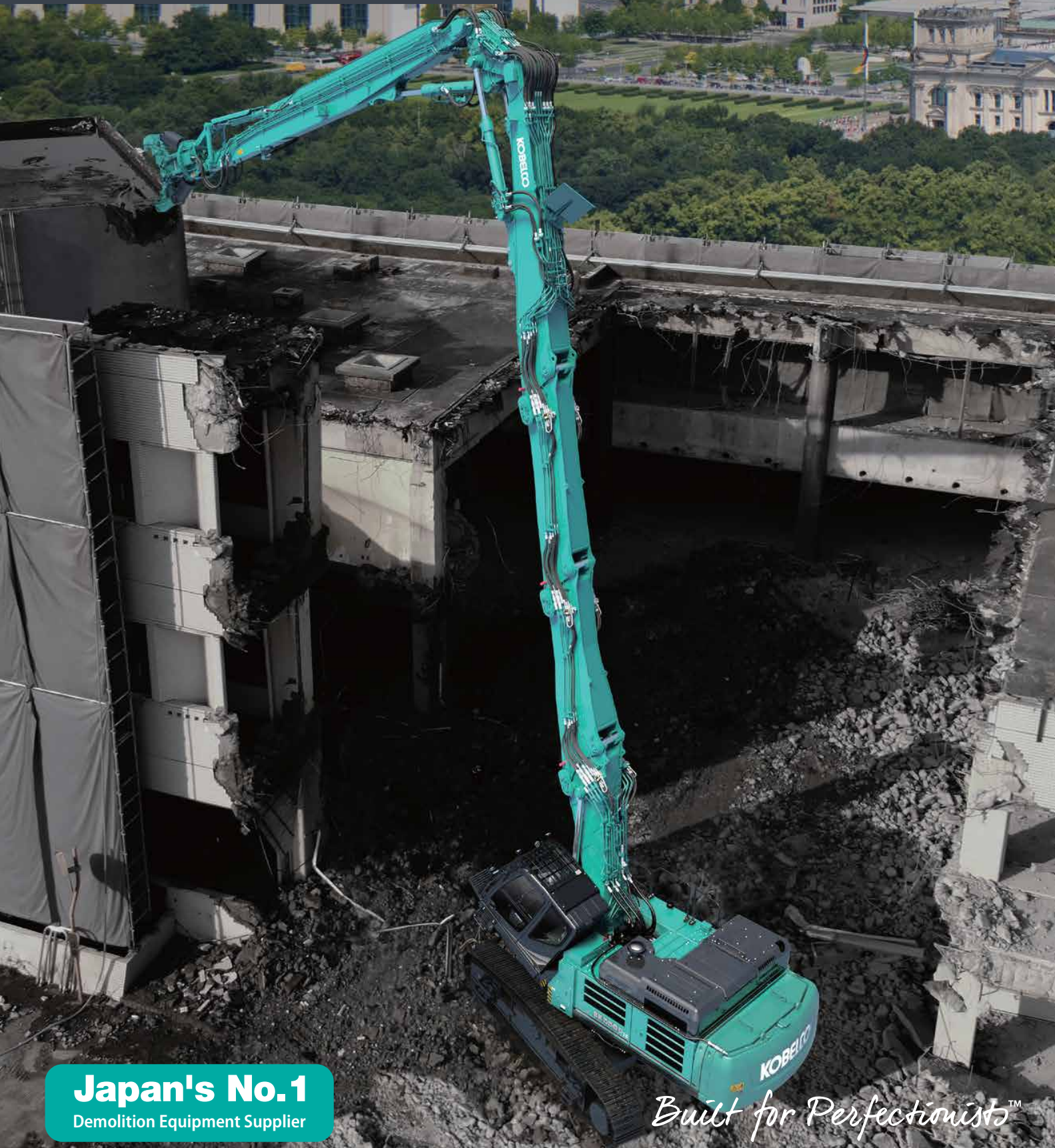

Japan's No.1
Demolition Equipment Supplier

Built for Perfectionists™

Performance X Design

PERFORMANCE — Constant pursuit of efficiency and productivity with more power, more speed.

DESIGN — Operator-centric with an uncompromising stance on good ease-of-use and comfort.

We've melded these principles to create the new 50ton class building demolition machine SK550DLC, the embodiment of all-new values.

Not just improved performance and design, this new dedicated machine sports new functionality and mechanism.

Once you experience this one-of-a-kind you will never forget, and that KOBELCO continues to push the bar higher.

SK550D_{LC}



To the Next Level of Power and Functional Aesthetics

High-output engine

Engine output is 10% or more higher than the previous model, and performance excels in all aspects of work.

Model : HINO E13CYM

Engine output
300kW/1,900min⁻¹
(ISO 14396)

Simple operation with the jog dial

Several operations combined in the jog dial.
Watch the screen associated with the dial, and then turn, select, push, and go. Simple!



New console tilt makes getting in and out easy

The design of the left console with safety lever takes getting in and out into consideration with a large-angle recoil.



Automatic lighting LED door light

A bright LED door light turns on in conjunction with opening the door and turning off the key.



Know everything at a glance: Large 10-inch colour monitor

Incorporates the industry's biggest large-format monitor.

The information you need is easy to see and operating the menus is simple.

The large camera image means you can quickly confirm safety conditions.

Exquisitely designed LED backlighting

Switches and dials are equipped with LED backlighting.

In addition to increasing recognizability at night, the lighting gives the interior a classy aura.

Specification selection

Select attachments to perform demolition from high heights to lower stories, and even basement levels with just one machine.

Ultra long attachment specification

Excels at demolishing aging five to eight story buildings

Uses a 3-piece ultra long attachment with cross-cylinder construction. By combining two types of arms and an optional boom insert, you can choose from a total of four attachment configurations to reach the heights you need. Ideal for demolition sites that require a height of 20m to 25m or more.

Maximum working height (arm top pin)

8.7m arm, with boom insert : **Approximately 27.5m**

6.1m arm, with boom insert : **Approximately 25.0m**

8.7m arm, no boom insert : **Approximately 24.0m**

6.1m arm, no boom insert : **Approximately 21.5m**



KOBELCO original nibbler KR1100TPR-2

- Maximum jaw opening width: 1,100mm
- Crushing force : 1,550kN (center) / 950kN (tip)
- Cutter length : 200mm
- Mass : 2,600kg

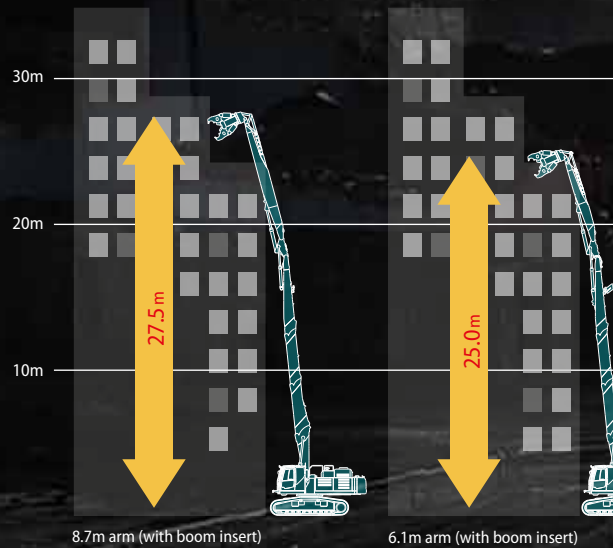

Separate boom specification

From low stories to basement level, hassle-free foundation demolition

With a wide working range, capable of demolishing lower stories and ground-level foundations. The wide opening width and strong crushing force of the large nibbler provides powerful and efficient demolition capabilities. The powerful attachment support provided by the large-diameter jib cylinder allows for efficient work at tall heights.



KOBELCO original nibbler KR1500TPR-50

- Maximum jaw opening width: 1,500mm
- Crushing force: 2,080kN (center) / 1,420kN (tip)
- Cutter length: 200mm
- Mass: 5,100kg

Working range (arm top pin)

Approximately
14.6m

Approximately
11.2m

Approximately
6.3m

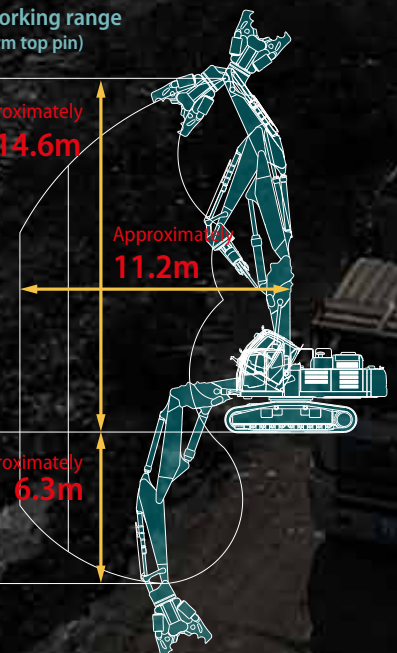

Transport of disassembled machine

Including NEXT attachments, incorporates KOBELCO's state-of-the-art assembly/disassembly technology.

Quick assembly NEXT attachments

Attaching a boom attachment to the main boom uses the NEXT joint system, consisting of a hook joint on the back and left-right separated manual pins on the belly. Safely and quickly assemble and disassemble.

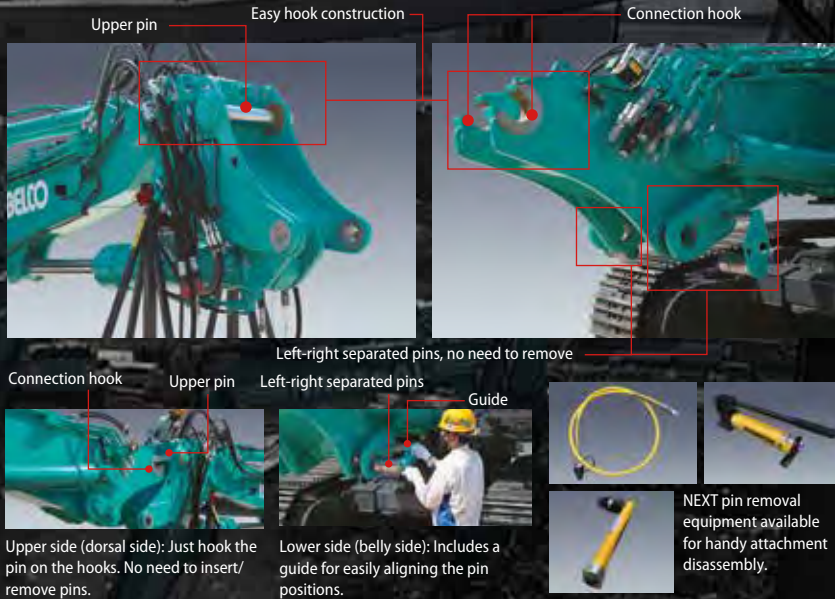

Upper side (dorsal side): Just hook the pin on the hooks. No need to insert/remove pins.

Lower side (belly side): Includes a guide for easily aligning the pin positions.

Object handling hook (OHK hook) is equipped as standard

Lifting hook equipped on the bucket link part with the separate boom specification. It can lift the ultra long attachment by itself, so no loading crane is necessary when changing attachments or loading/unloading the machine onto a transport truck.



Piping connection also simple with multi-coupler and other implements

With the attachment joint part, connect the hydraulic piping to the boom side, and then connect/disconnect with the multi-coupler or quick coupler. Safely and conveniently connect piping on the ground.



Multi-coupler

Quick-coupler

Quick hitch piping is equipped as standard

Dedicated piping is equipped as standard to attach the quick hitch for easy exchange of front attachments.



Attachment pressure drain from the display

Hydraulic oil pressure draining before exchanging the front attachment or disassembling the boom attachment can be done by selecting it on the display from the operator's seat.

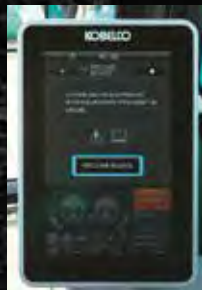

Crawler width changeable while grounded

A crawler extension/retraction mechanism is provided for retracting the lower width for trailer loading. Extension / retraction can be performed easily with the hydraulic mechanism while the machine is grounded with the shoes. No need to fasten any bolts.



Crawler width when retracted : **2,980m**

Separable counterweight for transport of disassembled machine

The counterweight is separable for easy attachment/detachment when transporting the base machine. Because it is constructed with the separable weight inside a case-style weight, removal can be done quickly.



Attachment height during transport

[NEXT Ultra long attachment specification]

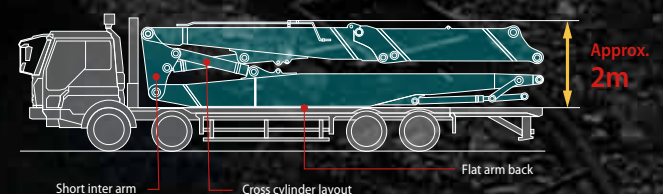

Note : Loading of lashing point

On the drive motor side, the brackets are attached to the top of the lower car body as lashing points to prevent interference between the piping cover and the binding wire.



Idler side

Drive Motor side

Reliability and safety

KOBELCO's latest technology for keeping the machine in top shape and protecting the operator.

Hydraulic drive for engine cooling fan; independent oil cooler fan

Hydraulic drive optimises the cooling fan rotation speed to improve fuel economy and reduce noise. Also, the independent oil cooler fan better matches cooling to the hydraulic oil temperature, for optimal oil temperature control.

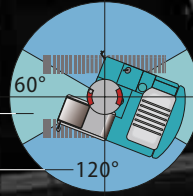

Stability warning system with longitudinal/horizontal detection

The device calculates the tipping danger area from the posture and swing angle of the attachment, and if it detects a dangerous situation, it alerts the operator with an alarm and a warning on the screen. By detecting longitudinal/lateral position of the upper structure, work can be done in a larger radius at the more stable, lateral upper structure direction.

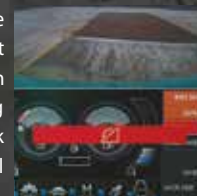

Stability warning display

A reverse fan to facilitate maintaining cooling performance

To prevent clogging that reduces cooling performance in parts like the radiator, oil cooler, or intercooler, a reverse fan has been added to blow away dust. Cooling devices can be cleaned with the flip of a switch, maintaining heat balance. This also renders burdensome and time consuming daily cleaning unnecessary.



LED work light to keep visibility in low light or at night

Equipped with six high brightness LED work lights. The lights keep the work area bright even in low light or at night. Work area safety can also be quickly confirmed.



Cab interference prevention system with soft-stop feature

If the attachment comes within a certain distance of the cab, an alarm and warning on the screen alert the operator, and the attachment stops softly and automatically to protect the operator. Since there is no worry of contact, the operator can confidently perform lever operation even close to the cab.

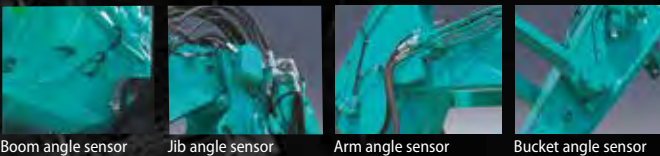

Cab interference warning display

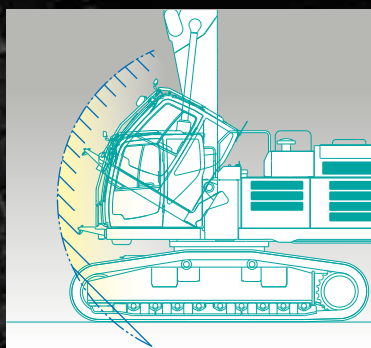

Right, left and rear view cameras / Eagle-Eye View

Cameras are equipped on the rear, right, and left sides of the base machine. Camera image is easily visible on the large 10-inch monitor. The blind spots behind and to the right can be checked in a glance from the operator's seat to confirm safety. The operator can choose how to display the camera image.



Comfort

A unique operating environment of building demolition machine to prevent operator fatigue.

Demolition spec cab with tilting function

A Demolition spec cab with a 30° tilt capability is equipped as standard for comfortably demolishing tall buildings where the operator spends a long time looking up. With no beam between the front window and skylight to block visibility and angled grids on the cab guard, good work visibility is maintained.



Easy to clean open/close cab guard (upper front window and skylight)



Vertical open/close roller shades to block direct sunlight.



High upper visibility



Cab tilt operation switch



36% larger front wiper wiping area (compared to standard cab)



Emergency manual valve for lowering cab



*Photo shows SK500 excavator

Air suspension seat

An air suspension seat is equipped as standard, with excellent shock absorption to prevent fatigue even when sitting for a long time. It includes a wide four-inch arm rest that allows you to take a comfortable position and a seat heater for comfortable operation even in winter season.

Equipment

For ensuring the machine remains safely usable for a long time.



Reinforced upper frame under cover guards
6mm-thick steel plate cover protects devices in the base machine.



Lower frame guard
9mm-thick steel plate cover protects travel-system hydraulic circuits.



Safety valve for boom & arm jib cylinder
Prevents attachment from falling if piping is ruptured.



Bucket cylinder guard
Prevents damage to the cylinder from falling debris.



Full truck guide (option)
Prevents treads from coming off when mounting on demolition rubble.



Public address system
Alert workers in the area with clear audio quality.



Cab lower mirror
Check safety at foot areas and under the cab when tilted.



Cab entry step
Positioned for convenient access to the tilt cab.



Refueling pump
Quickly and safely refuel from the ground.



Auto lubrication system
Quickly lubricate the attachments.



Water spray
Drain circuit is provided for rust prevention.



Additional storage box
Equipped with a storage box for storing tools and implements.



Falling object deflector
The guard deflects falling debris away from the machine. This is standard for the ultra long attachment.

* The accessory settings may differ according to the specification. Refer to the list of key accessories on the back page for details.



Engine

Model	HINO E13CYM
Type	Four-stroke liquid-cooled direct injection type diesel engine with intercooler turbo-charger.
No. of cylinders	6
Bore and stroke	137 mm x 146 mm
Displacement	12.913 L
Rated power output	300 kW / 1,900 min ⁻¹ (ISO 14396: without fan)
Max. torque	1,700 N-m/1,400 min ⁻¹ (ISO 14396: without fan)



Hydraulic system

Pump	
Type	Two variable displacement piston pumps + extra pump + pilot pump
Max. discharge flow	2 x 370 L/min 1 x 61.8 L/min, 1 x 28.5 L/min
Relief valve setting	
Boom, arm and bucket	31.4 MPa
Power Boost	34.3 MPa (for Separate Boom)
Travel circuit	34.3 MPa
Swing circuit	26.0 MPa
Control circuit	5.0 MPa
Nibbler (Crusher) circuit	31.4 MPa (Open & Close) 20.6 MPa (Rotation)
Pilot control pump	Gear type
Main control valves	8-spool
Oil cooler	Air cooled type



Swing system

Swing motor	Two fixed displacement piston motor
Brake	Hydraulic; locking automatically when the swing control lever is in the neutral position
Parking brake	Wet multiple plate
Swing speed	4.0 min ⁻¹ (Ultra long attachment) 7.5 min ⁻¹ (Separate boom)
Tail swing radius	3,970 mm
Swing torque	188 kN-m



Travel system

Travel motors	Variable displacement piston motor with counterbalance valve
Travel brakes	Hydraulic brake
Parking brakes	Wet multiple plate
Travel shoes	50 each side
Travel speed (high / low)	5.4 / 3.2 km/h
Drawbar pulling force	415 kN (SAE)
Gradeability	70% {35°}



Cab & control

Cab
All-weather, sound-suppressed steel cab mounted on the silicon-sealed viscous mounts and equipped with a heavy, insulated floor mat. Demolition spec cab with tilting function (30°)

Control
Two hand levers and two foot pedals for travel
Two hand levers and one foot pedal for excavating and swing
Electric rotary-type engine throttle

Noise levels	
External	106 dB(A) (2000/14/EC)
Operator	69 dB(A) (ISO 6396)
Vibration levels	
Hand/arm*	≤ 2.5 m/s ²
Body*	≤ 0.5 m/s ²

* For the risk assessment according to 2002/44/EC, refer to ISO/TR 25398: 2006.



Boom, arm & bucket

bore x stroke (mm)

Attachment type	NEXT Ultra long attachment
Boom cylinders	180 x 1,580
Jib cylinders	140 x 1,210
Arm cylinder	170 x 1,210
Bucket cylinder	125 x 1,200
Attachment type	Separate attachment
Boom cylinders	180 x 1,580
Jib cylinder	270 x 1,418
Arm cylinder	190 x 1,970
Bucket cylinder	160 x 1,410



Refilling capacities & lubrications

Fuel tank	638 L
Cooling system	70 L
Engine oil	58 L
Travel reduction gear	2 x 15.0 L
Swing reduction gear	2 x 5.0 L
Hydraulic oil tank	371 L tank oil level
	720 L hydraulic system
DEF / Urea tank	83 L

Operating Weight & Ground Pressure

Attachment type	NEXT Ultra long attachment/equipment*		Separate attachment*
	6.1m arm (25m height)	8.7m arm (27.5m height)	
Operating weight	63,500 kg	64,000 kg	65,500 kg
Ground pressure	109 kPa	110 kPa	112 kPa

* Measured with max tool weight

Attachments

Nibbler

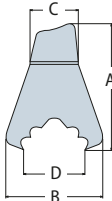
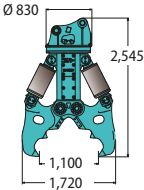
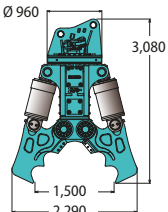
Model		KR1100TPR-2	KR1500TPR-50	
Weight	kg	2,600	5,100	
Dimensions	 <p>A Overall length B Width C Diameter D Jaw opening width</p>			
	Blade length	mm	200	200
Crushing force	Top	kN	950	1,420
	Center	kN	1,550	2,080
Assemble dimensions	Arm top width	mm	325	450
	Pin diameter	mm	80	100
Working hydraulic pressure	MPa	34.3	29.4	

Note: Units follow the International System of Units (SI).

Dimensions

Dimensions (base machine + base boom)

Unit: mm

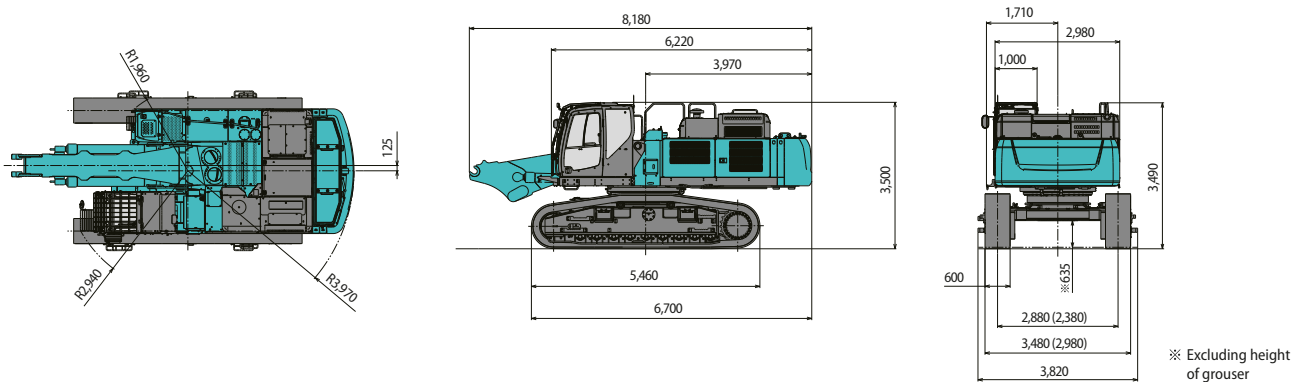

Assembled machine dimensions

Unit: mm

- NEXT Ultra long attachment specification : 8.7m arm + 3.5m boom insert

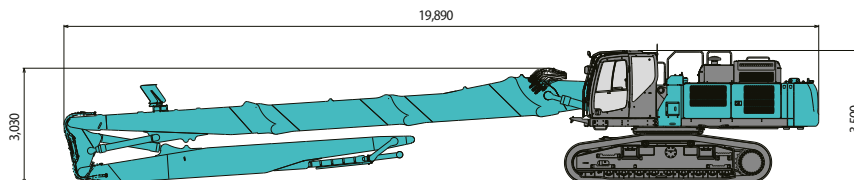

- NEXT Ultra long attachment specification : 6.1m arm + 3.5m boom insert

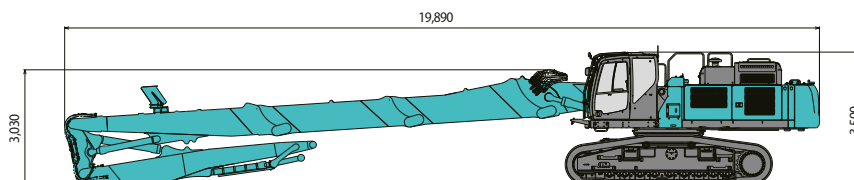

- NEXT Separate boom specification

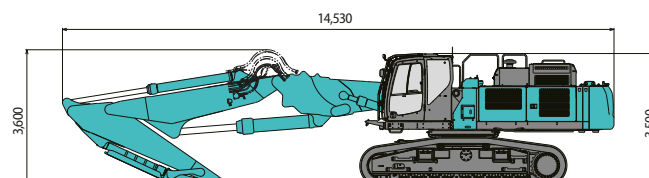

Specifications

Disassembled dimensions and weight

Unit: mm

<p>Base machine + base boom</p> <p>Weight: 51,700 kg</p>	<p>Base machine + base boom (without counterweight)</p> <p>Weight: 40,500 kg</p>	<p>Counterweight Case</p> <p>Weight: 4,810 kg</p>
<p>Counterweight</p> <p>Weight: 6,260 kg</p>	<p>NEXT Ultra long attachment : 8.7m arm + 3.5m boom insert (including enclosed stand)</p> <p>Overall width: 1,770 mm Weight: 8,180 kg</p>	<p>NEXT Ultra long attachment : 8.7m arm (including enclosed stand)</p> <p>Overall width: 1,770 mm Weight: 6,480 kg</p>
<p>NEXT Ultra long attachment : 6.1m arm + 3.5m boom insert (including enclosed stand)</p> <p>Overall width: 1,770 mm Weight: 7,670 kg</p>	<p>NEXT Ultra long attachment : 6.1m arm (including enclosed stand)</p> <p>Overall width: 1,770 mm Weight: 5,970 kg</p>	<p>NEXT Ultra long attachment : 3.5m boom insert (including optional stand)</p> <p>Overall width: 1,770 mm Weight: 1,970 kg</p>
<p>NEXT Ultra long attachment : 3.5m boom adapter (including optional stand)</p> <p>Overall width: 1,850 mm Weight: 2,070 kg</p>	<p>NEXT Separate boom (including enclosed stand)</p> <p>Overall width: 1,850 mm Weight: 8,790 kg</p>	

Lift Capacities

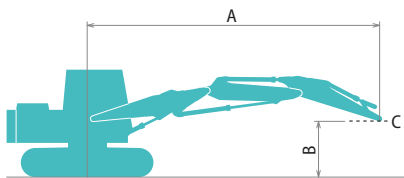

Rating over front



Rating over side or 90 degrees

A – Reach from swing centerline to arm top
B – Arm top pin height above/below ground
C – Lift point
Relief valve setting: 34.3 MPa

Unit : kg

		Boom: Separate boom		Arm: 3.45 m		Front attachment: without		Counterweight: 11,100 kg		Shoe: 600 mm (Heavy Lift)				At Max. Reach		Radius		
B Height	Radius A	3.0 m		4.5 m		6.0 m		7.5 m		9.0 m		10.5 m		12.0 m				
		Rating over front	Rating over side or 90 degrees	Rating over front	Rating over side or 90 degrees	Rating over front	Rating over side or 90 degrees	Rating over front	Rating over side or 90 degrees	Rating over front	Rating over side or 90 degrees	Rating over front	Rating over side or 90 degrees	Rating over front	Rating over side or 90 degrees			
13.5 m				*15,790	*15,790											*14,090	*14,090	5.87 m
12.0 m						*13,200	*13,200	*10,600	*10,600							*10,950	*10,950	8.14 m
10.5 m						*11,610	*11,610	*8,620	*8,620	*9,170	*9,170					*9,440	8,540	9.66 m
9.0 m				*9,580	*9,580	*11,300	*11,300	*11,380	*11,380	*8,180	*8,180	*8,550	7,370			*8,560	6,950	10.76 m
7.5 m				*19,300	*19,300	*14,370	*14,370	*11,760	*11,760	*7,790	*7,790	*8,050	7,310			*7,960	6,000	11.56 m
6.0 m				*18,440	*18,440	*15,550	*15,550	*8,450	*8,450	*7,910	*7,910	*7,960	7,070	5,520		*7,490	5,400	12.12 m
4.5 m				*15,830	*15,830	*11,500	*11,500	*9,520	*9,520	*8,490	*8,490	*8,140	6,770	*7,530	5,410	*7,090	5,040	12.47 m
3.0 m				*16,720	*16,720	*13,640	*13,640	*10,740	10,340	*9,210	8,100	*8,490	6,490	*7,380	5,280	*6,700	4,850	12.63 m
1.5 m				*13,770	*13,770	*15,420	13,870	*11,880	9,870	*9,930	7,750	*8,540	6,270	*7,050	5,170	*6,270	4,820	12.61 m
G.L.				*17,830	*17,830	*14,530	13,590	*11,600	9,680	*9,710	7,570	*8,060	6,140	*6,420	5,140	*5,760	4,950	12.40 m
-1.5 m	*14,900	*14,900	*23,320	22,640	*10,550	*10,550	*10,280	9,710	*8,750	7,540	*7,190	6,140	*5,110	*5,110	*5,080	*5,080	12.01 m	
-3.0 m	*22,110	*22,110	*22,600	*22,600	*16,910	14,680	*8,470	*8,470	*7,280	*7,280	*5,730	*5,730			*4,140	*4,140	11.40 m	
-4.5 m	*29,300	*29,300	*20,990	*20,990	*15,960	14,930	*8,450	*8,450	*6,820	*6,820					*12,590	11,080	7.43 m	
-6.0 m			*17,720	*17,720	*12,010	*12,010									*14,350	*14,350	5.62 m	

Notes:

- Do not attempt to lift or hold any load that is greater than these lift capacities at their specified lift point radius and height. Weight of all accessories must be deducted from the above lift capacities.
- Lift capacities are based on machine standing on level, firm, and uniform ground. User must make allowance for job conditions such as soft or uneven ground out of level conditions, side loads, sudden stopping of loads, hazardous conditions, experience of personnel, etc.
- Arm top pin is defined as lift point.
- The above lift capacities are in compliance with SAE J/ISO 10567. They do not exceed 87 % of hydraulic lift capacity or 75 % of tipping load. Lifting capacities marked with an asterisk (*) are limited by hydraulic capacity rather than tipping load.
- Operator should be fully acquainted with the operator's and Maintenance Instructions before operating this machine and rules for safe operation of equipment should be adhered to at all times.
- Lift capacities apply to only machine as originally manufactured and normally equipped by KOBELCO CONSTRUCTION MACHINERY CO., LTD.
- This table cannot be applied for high reach demolition machines.



Working Ranges

NEXT Ultra long attachment specification : 8.7m arm + 3.5m boom insert

Max. tool weight = 2,600kg

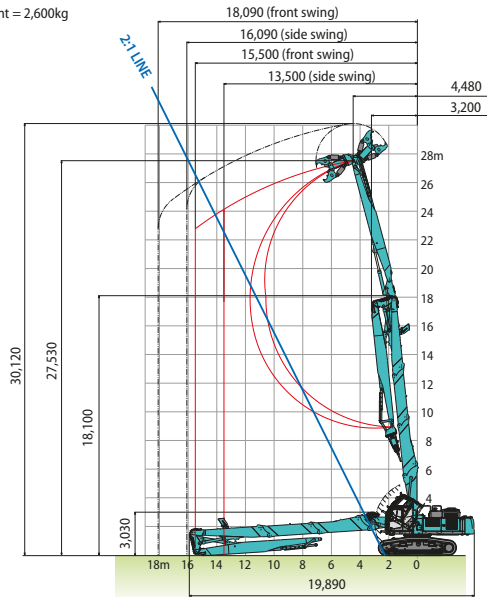

NEXT Ultra long attachment specification : 8.7m arm

Max. tool weight = 2,600kg

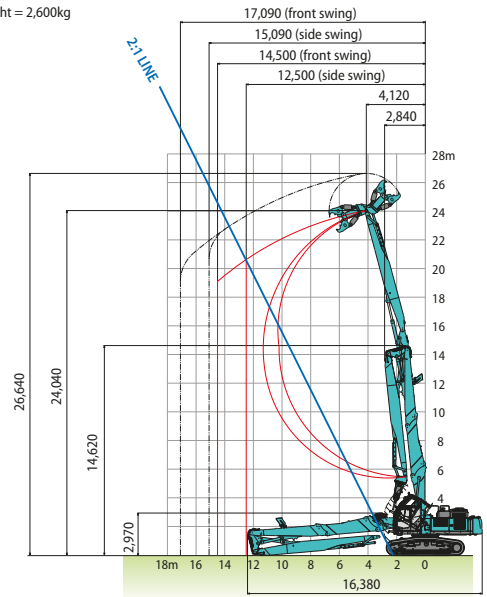

NEXT Ultra long attachment specification : 6.1m arm + 3.5m boom insert

Max. tool weight = 3,000kg

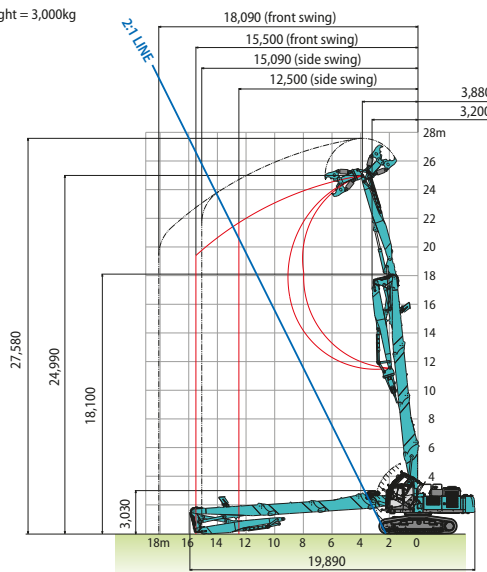

NEXT Ultra long attachment specification : 6.1m arm

Max. tool weight = 3,000kg

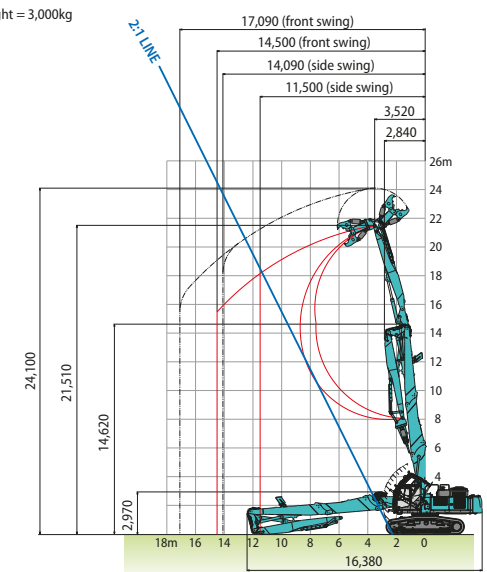

NEXT Separate boom specification

Max. tool weight = 5,300kg

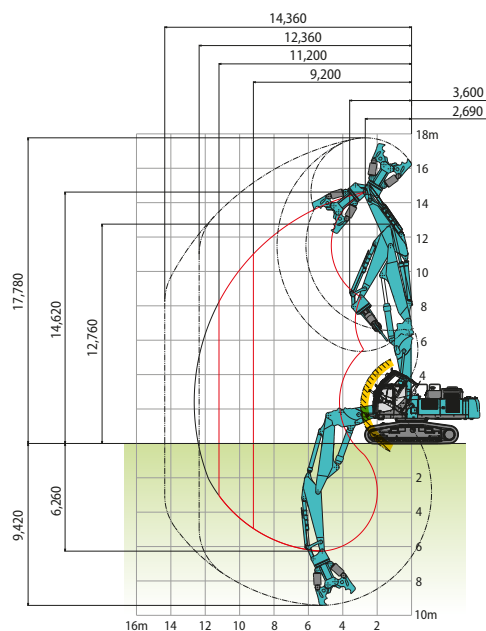

*Cab interference prevention system operating area.

Standard and Optional Equipment

● =Std ○ =Opt. - = not available

Category	Description	SK550DLC-11		
		Separate boom Attachment	Ultra long Attachment (25m height)	Ultra long Attachment (27.5m height)
ENGINE	Hino E13CYM	●	●	●
	Exhaust DOC DPF SCR system	●	●	●
	Alternator 24 V /90 A	●	●	●
	Starter motor 24 V/7 kW	●	●	●
	Batteries 2x 12V (176Ah)	●	●	●
	Reversible hydraulic drive cooling fan	●	●	●
	Auto deceleration function	●	●	●
	Auto idle stop	●	●	●
HYDRAULIC SYSTEM	3 work modes H, S, Eco	●	●	●
	Power boost (34.3MPa)	●	—	—
	Heavy lift mode	●	—	—
	Pressure release function	●	●	●
	Independent travel function	●	●	●
	Auto warm up system	●	●	●
	Proportional Hand Control (for Rotation & N&B piping)	●	●	●
	Hydraulic oil VG32	●	●	●
	Hydraulic oil VG46	○	○	○
	Hydraulic oil VG68	○	○	○
PIPING	Rotation & N&B piping	●	●	●
	QH piping	●	●	●
CABIN	Air suspension seat with heating	●	●	●
	10 inch colour monitor	●	●	●
	LED door light	●	●	●
	Air-conditioner	●	●	●
	DAB+ radio (FM/AM & AUX & USB & Bluetooth® & hands free telephone)	●	●	●
	Harness for cab four lights and cab yellow flasher	●	●	●
LIGHTS	Parallel wiper	●	●	●
	12V power supply	●	●	●
	LED work lights ; 2 on cab top & 1 on cab bottom & 1 on upper structure	●	●	●
	LED work lights ; 2 on boom	●	—	—
WORKING EQUIPMENT	LED work lights ; 2 on arm	—	—	—
	NEXT Separate boom attachment package	●	○	○
	NEXT Ultra Long attachment package for 25m pin height	○	●	○
	NEXT Ultra Long attachment package for 27.5m pin height	○	○	●
	NEXT water spray (water pump & tank are not included)	●	●	●
	Kobelco original Nibbler KR1100TPR (for Ultra Long attachment)	—	○	○
	Kobelco original Nibbler KR1500TPR (for Separate boom attachment)	○	—	—
C/W	OHK hook	●	—	—
	Layered C/W (TTL 11,100kg)	●	●	●
UNDERCARRIAGE	VLC (Hydraulic variable undercarriage)	●	●	●
	600mm triple grouser shoe	●	●	●
	600mm double grouser HD shoe	○	○	○
	Track guides (two per side)	●	●	●
	Full track guide	○	○	○
SAFETY	Lower frame guard	○	○	○
	Engine emergency stop switch	●	●	●
	Pump emergency mode (KPSS release switch)	●	●	●
	Emergency accel dial	●	●	●
	Emergency manual valve for lowering attachment	●	●	●
	Emergency manual valve for lowering cab	●	●	●
	Over load alarm	●	—	—
	Safety valve for boom & arm & jib cylinder	●	●	●
	Demolition spec cab (P5A glass, Tilting function)	●	●	●
	OPG Level II top guard (ISO 10262;1998)	●	●	●
	OPG Level II front guard (ISO 10262;1998)	●	●	●
	Eagle-eye view camera (Rear, Right, Left)	●	●	●
	Cab lower mirror	●	●	●
	Falling object deflector	—	●	●
	Seatbelt indicator on display	●	●	●
	Travel alarm	●	●	●
OTHERS	Cab interference prevention system	●	●	●
	Stability warning system	●	●	●
	Public address system	●	●	●
	Refueling pump	●	●	●
	Auto lubrication system	●	●	●
	Harness for engine room light	●	●	●
	NEXT pin removal equipment	●	●	●
	NEXT stand for 3.5m insert boom	○	○	○
	NEXT stand for 3.5m adapter	○	○	○
	Additional storage box	●	●	●
Bucket cylinder guard	●	●	●	
RAL colour	○	○	○	
KOMEXS	●	●	●	

Note: Standard and optional equipment may vary. Consult your KOBELCO dealer for specifics. Bluetooth is a registered trademark of the Bluetooth SIG Inc.

Note: This catalogue may contain attachments and optional equipment that are not available in your area. And it may contain photographs of machines with specifications that differ from those of machines sold in your areas. Please consult your nearest KOBELCO distributor for those items you require. Due to our policy of continuous product improvements all designs and specifications are subject to change without advance notice.

Copyright by **KOBELCO CONSTRUCTION MACHINERY CO., LTD.** No part of this catalogue may be reproduced in any manner without notice.

KOBELCO CONSTRUCTION MACHINERY EUROPE B.V.

Veluwezoom 15
1327 AE Almere
The Netherlands
www.kobelco-europe.com

Enquiries To: