

KOBELCO

Performance  Design

SK240 SN

- Bucket capacity:
0.70 – 0.80 m³
- Engine power:
127 kW / 2,000 min⁻¹
- Operating weight:
23,600 – 24,600 kg



Complies with the EU Stage V
exhaust emission regulation

Built for Perfectionists™



Performance X Design

SK240SN-11E of KOBELCO has realised a completely new value by harmonising PERFORMANCE – greater efficiency and productivity with an increased power and speed and DESIGN – operator-based operability and comfort, refusing to accept any compromises.

In pursuit of unique and matchless machines which are unforgettable once you use them, KOBELCO will continue to rise to meet every challenge.



THE ULTIMATE IN SIMPLE AND ELEGANT DESIGN

Our pursuit of functional beauty and aesthetic sense produced a new interior design.

Jog dial

This jog dial integrates multiple functions to realise simple operations. Even with gloved hands, the operator can set various machine conditions without stress.

LED backlights

The switches and dials have LED backlights – they provide a bright, clear view in the dark and set a luxurious mood.







UNFORGETTABLE COMFORT

Air suspension seat with heating

A GRAMMER* seat is installed as standard equipment, which achieves excellent shock absorption and superior ride comfort.

*GRAMMER is trademark of GRAMMER AG, registered in Germany and other countries.

Air-conditioner

Air is blown against the operator's waist and the back of their head, offering more comfortable operation.

Lever angles allow for comfortable operations

The operator can move the levers horizontally without twisting their wrist, which reduces the fatigue caused by the operations.



New Hydraulic Control

Our newly upgraded hydraulic control system responds to shorter lever strokes than current models, delivering swifter, more precise movement and improved lever operability.

LED door light

The LED interior light automatically turns on when the door is opened or when the ignition is set to OFF. This ensures easy entry and exit at nighttime.

Parallel wipers secure a wide field of view



KOBELCO



04:33



SETTING MENU



PICTURE OF CAMERA



CLOCK SETTING



SCREEN BRIGHTNESS



MAINTENANCE



CONSUMPTION



LANGUAGE SELECTION



PRESSURE RELEASE



SAFETY ON FULL DISPLAY

Standard 3 Sides Safety Camera System

Our high-resolution, large display shows right, left and rear side cameras together. Multiple display allows the operator to customize viewing needs to enhance operator awareness and jobsite safety.

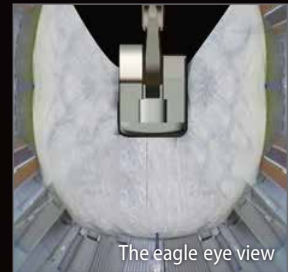
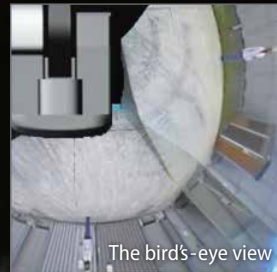
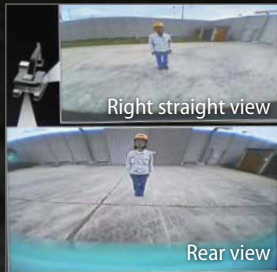

Large 10-Inch Color Monitor

The easy-to-operate menu screen and recognizable icons assist the operator to select the most important information needed to ensure jobsite safety and machine control.



Dial in the Right Information

Simply turn the jog dial to the right or left to select an operational feature, then press the dial to confirm selection.





Independent Travel

Selecting Independent Travel dedicates one hydraulic pump to travel and one to the attachment on a continuous basis, allowing for a smooth and constant movement speed even while swinging or using the boom or attachment. With Independent Travel, safely carrying a large pipe across a job site is a breeze.

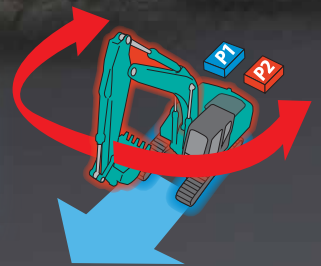

EXPERIENCING A COMPETENT PERFORMANCE

Higher Efficiency, plus a EU Stage V Compliant Engine

The new SK240SN is equipped with a Yanmar Stage V compliant engine, which has a higher torque value. Superior balance between engine output and torque contributes to more efficient performance than the previous models. In addition, the DPF replacement interval has been extended.

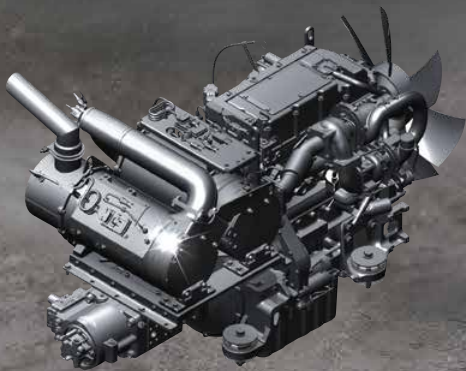

Model: YANMAR 4TN107FTT

Engine output

127 kW / 2,000 min⁻¹



»» Max. bucket digging force (Arm 2.94 m)

Normal: **143** kN

With Power Boost: **157** kN

Lift capacity

11,890 kg

(Reach: 4.50 m Boom: 5.65 m Arm: 2.94 m Bucket: Without Counterweight: 4,900 kg Shoe: 550 mm <Heavy Lift>)

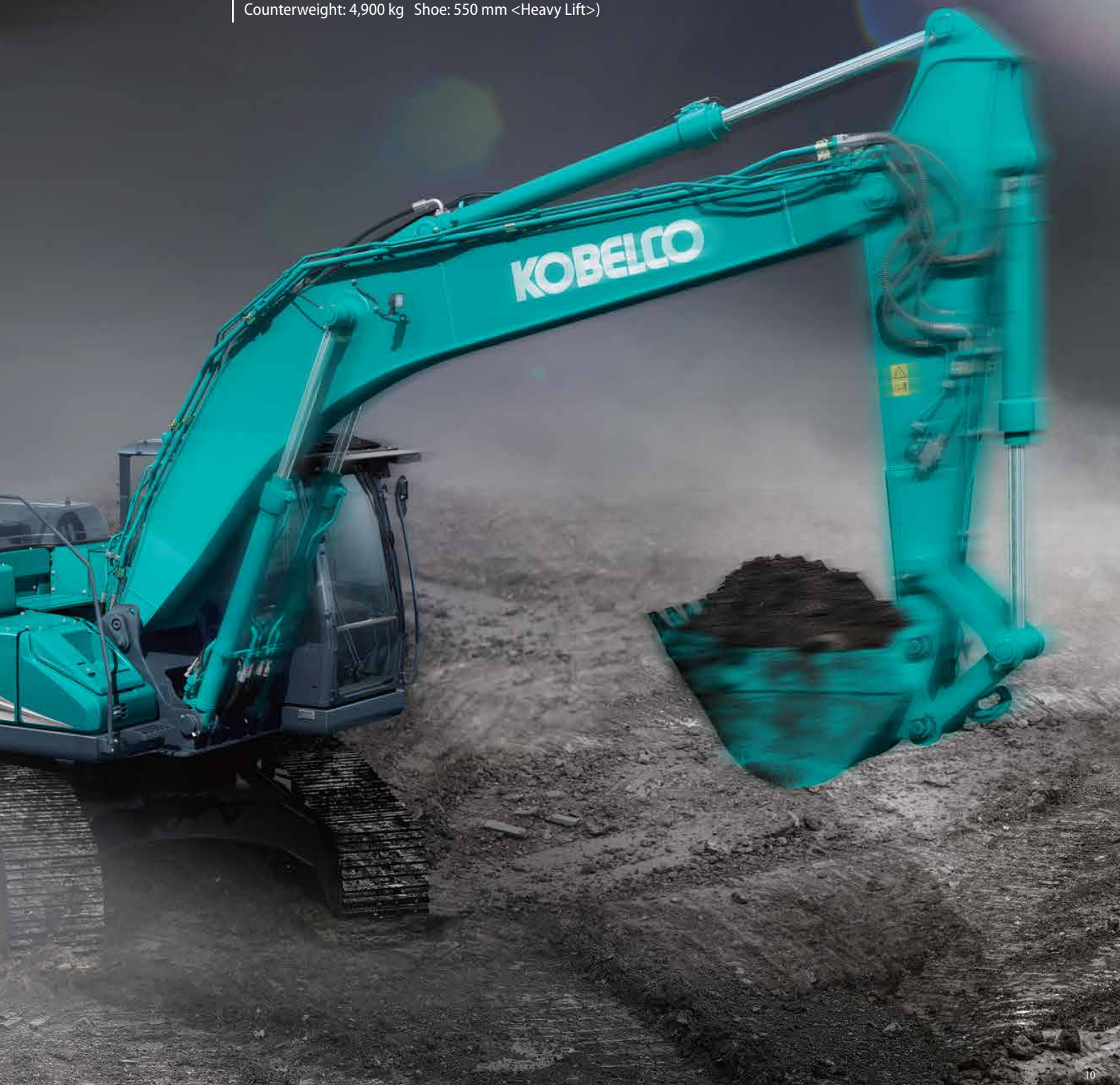

GREATER MULTI-FUNCTION CAPABILITIES

Attachment mode

The flow rate and working pressure modes of the bucket, breaker, nibbler, and rotating grapple are set before delivery, which allows you to start operating immediately. Mode settings for other attachments, such as the tilt rotator, can easily be added or changed.

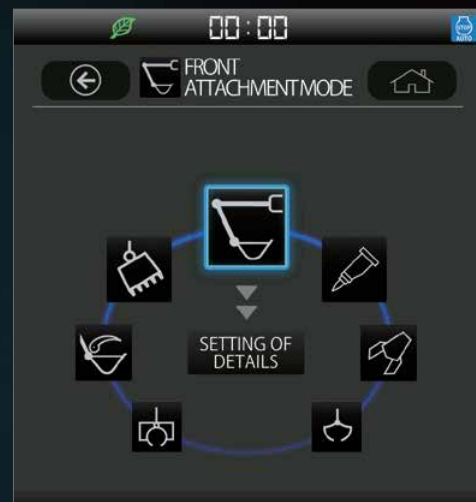

EASY MAINTENANCE



Standard Overhead Top Guard Level II

The standard overhead cab guard can be tilted open with gas damper for easy window cleaning. Meets standard top guard level II requirements (ISO 10262).



Engine Maintenance

Lower service platform makes engine service easier.



Two-stage air filter



DEF/AdBlue[®] Tank

The DEF/AdBlue[®] fill is located inside the locking tool box.



Left side (radiator and cooling system elements)

Laid out for easy access to radiator and cooling system.



Right Side (Ground Level Maintenance)

Hydraulic pump and engine filter compartment.



Fuel Filter/Pre-Filter with Integrated Water Separator



Engine Oil Filter

Note: AdBlue[®] is a registered trademark of the Verband der Automobilindustrie e.V. (VDA).

DURABILITY YOU CAN TRUST

Enhanced body rigidity for 25-ton class machines

The SK240SN machines are widely used in mid-scale construction projects and harsh worksites. The components have been reviewed and improvements have been made to their durability to ensure stable performance in such environments.



Panels and supports

The right and left side panels and rear supports have been thicker to enhance body rigidity.



Bucket cylinder rod pin

The increased diameter of the bucket cylinder rod pin contributes to enhanced durability for various types of attachments.

Crawlers Built for Unbeatable Durability



Standard HD Shoes and Track Link

Reinforced HD shoes of thick steel plate to master rough, stony ground.



Three Track Guides Each Side

Large, reinforced track guide is installed.



Reinforced Travel Motor Cover

Rear of travel motor cover is reinforced.



Lower Under Cover

Hydraulic piping and equipment protected against damage from rubble and stony ground.

CONVENIENT AND SENSIBLE EQUIPMENT



Engine start password

A password is required when starting the engine for greater security.



Wiper adjustment function

In addition to the intermittent wiper mode and continuous wiper mode, the one-time wiper mode was added.



Parallel wiper

Sun screen (Option)



Console mount

The console-integrated seat allows for comfortable operation.



DAB+ radio (FM/AM & AUX & USB & Bluetooth® & hands-free telephone)



USB port/12V power supply



Smartphone holder

You can use the holder with your smartphone connected to the USB port.

Note: Bluetooth® is a registered trademark of the Bluetooth SIG Inc.

COMPLYING WITH TRANSPORT REGULATIONS

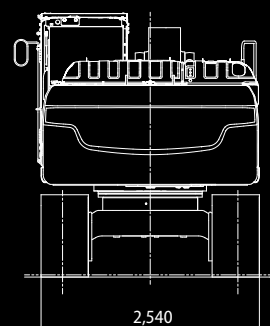
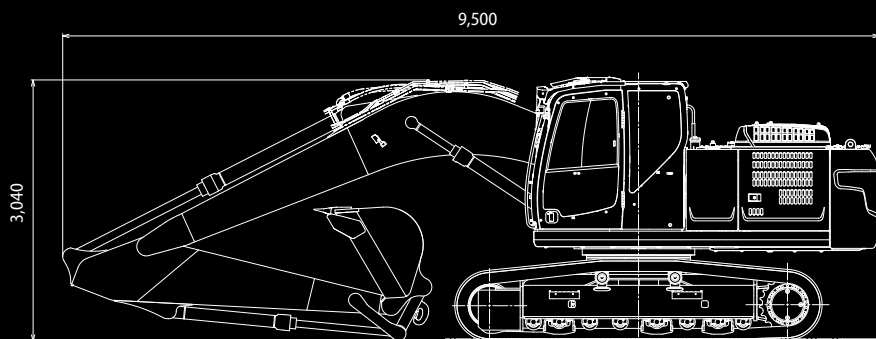

*Values are for 2.94m arm



KOBELCO MONITORING EXCAVATOR SYSTEM

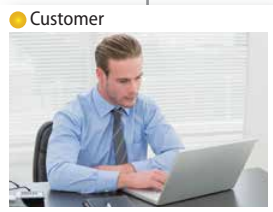

Remote Monitoring for Peace of Mind

KOMEXS (Kobelco Monitoring Excavator System) uses satellite communication and internet to relay data, and therefore can be deployed in areas where other forms of communication are difficult. When a hydraulic excavator is fitted with this system, data on the machine's operation, such as operating hours, location, fuel consumption, and maintenance status can be obtained remotely.

Direct Access to Operational Status

Location Data

Accurate location data can be obtained even from sites where communications are difficult.

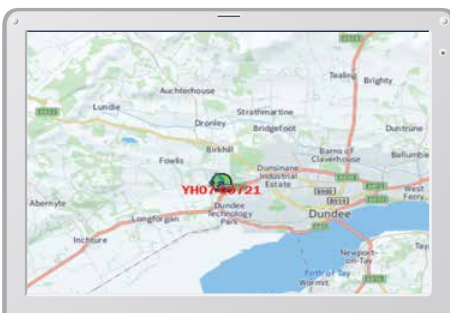

Latest location

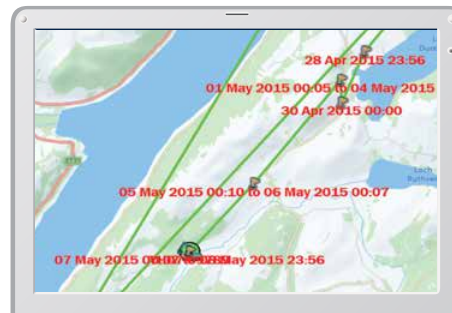

Location records

Type of Operation	Working Hrs	Ratio
Total Working Hrs	169 Hrs	100 %
Digging Hrs	72.2 Hrs	43 %
Traveling Hrs	18.3 Hrs	11 %
Idle Hrs	15.9 Hrs	9 %
Opt Att Hrs	62.5 Hrs	37 %
Crane Mode Hrs	0 Hrs	0 %

Work data

Operating Hours

- A comparison of operating times of machines at multiple locations shows which locations are busier and more profitable.
- Operating hours on site can be accurately recorded, for running time calculations needed for rental machines, etc.

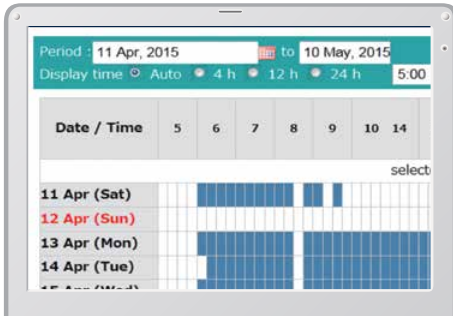

Daily report

Fuel Consumption Data

Data on fuel consumption and idling times can be used to indicate improvements in fuel consumption.

Work mode	Working Hrs	Total Fuel Consumption
H mode	2:06	24.5 L
S mode	0:00	0.0 L
E mode	169:19	1489.7 L
TOTAL	171:25	1514.2 L

Fuel consumption

Graph of Work Content

The graph shows how working hours are divided among different operating categories, including digging, idling, travelling and optional operations.

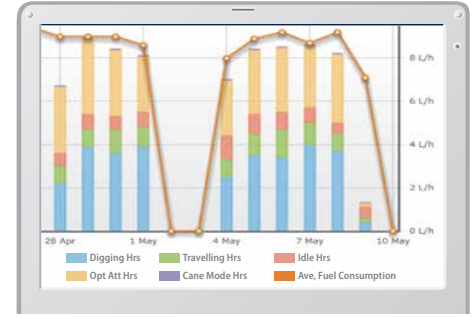

Work status

Maintenance Data and Warning Alerts

Machine Maintenance Data

- Provides maintenance status of separate machines operating at multiple sites.
- Maintenance data is also relayed to KOBELCO service personnel, for more efficient planning of periodic servicing.

Model	Serial No.	Hour Meter	Engine Oil
SK135SRLC-3/SK140SRL	YH07-09721	734 Hr	434
SK135SRLC-3/SK140SRL	YH07-09789	73 Hr	429
SK210LC-9	YQ13-10454	960 Hr	58
SK210LC-9	YQ13-10481	549 Hr	498
SK75SR-	YT08-30374		

Maintenance

Warning Alerts

This system warns an alert if an anomaly is sensed, preventing damage that could result in machine downtime.

Alarm Information Can Be Received through E-mail

Alarm information or maintenance notice can be received through E-mail, using a computer or cell phone.



Alarm messages can be received on mobile device.

Daily/Monthly Reports

Operational data downloaded onto a computer helps in formulating daily and monthly reports.

Security System

Engine Start Alarm

The system can be set an alarm if the machine is operated outside designated time.

Setting Condition

Setting Condition Change

Start time 20 : 00

Release time 07 : 00

No Working Whole Day

Mon Tue Wed Thu Fri Sat Sun

Clear

Engine start alarm outside prescribed work time

Area Alarm

It can be set an alarm if the machine is moved out of its designated area to another location.

Setting Condition

Around the current (latest) location 1 Km

Input Latitude and Longitude

Latitude1

Longitude1

Latitude2

Longitude2

Map Clear

Release

Alarm for outside of reset area

Specifications

Engine

Model	YANMAR 4TN107FTT
Type	Direct Injection, water-cooled, 4cylinder diesel engine with turbocharger, intercooler complies with EU stage V exhaust emission regulation
No. of cylinders	4
Bore and stroke	107 mm × 127 mm
Displacement	4.567 L
Rated power output	122 kW /2,000 min ⁻¹ (ISO 9249: with fan)
	127 kW /2,000 min ⁻¹ (ISO 14396: without fan)
Max. torque	791 N·m /1,500 min ⁻¹ (ISO 9249: with fan)
	805 N·m /1,500 min ⁻¹ (ISO 14396: without fan)

Hydraulic system

Pump	
Type	Axial piston pumps + extra gear pump + pilot gear pump
Max. discharge flow	2 × 220 L/min, 1 × 40.6 L/min, 1 × 20 L/min
Relief valve setting	
Boom, arm and bucket	34.3 Mpa {350 kgf/cm ² }
Power Boost	37.8 Mpa {385 kgf/cm ² }
Travel circuit	34.3 Mpa {350 kgf/cm ² }
Swing circuit	29.0 Mpa {296 kgf/cm ² }
Control circuit	5.0 Mpa {50 kgf/cm ² }
Pilot control pump	Gear type
Main control valve	8 - Spool valve
Oil cooler	Air cooled type

Swing system

Swing motor	One fixed displacement piston motor
Brake	Hydraulic; locking automatically when the swing control lever is in neutral position
Parking brake	Oil disc brake, hydraulic operated automatically
Swing speed	12.7 min ⁻¹
Swing torque	73.0 kNm

Attachments

Backhoe bucket and combination

Use	Backhoe bucket			
		Normal digging		
Bucket capacity	ISO heaped	m ³	0.70	0.80
	With side cutter	mm	1,080	1,160
Opening width	Without side cutter	mm	980	1,140
	No. of teeth		5	5
Bucket weight		kg	630	660
Combination	2.40 m short arm		○	○
	2.94 m standard arm		○	◎

◎ Standard ○ Recommended

Travel system

Travel motors	2 × axial-piston, two-step motors
Travel brakes	Hydraulic brake per motor
Parking brakes	Oil disc brake per motor
Travel shoes	47 each side
Travel speed	6.0 / 3.6 km/h
Drawbar pulling force	228 kN (SAE)
Gradeability	70 % {35°}

Cab & control

Cab

All-weather, sound-suppressed steel cab mounted on the high suspension mounts filled with silicone oil and equipped with a heavy, insulated floor mat.

Control

Two hand levers and two foot pedals for travel

Two hand levers for excavating and swing

Electric rotary-type engine throttle

Noise levels

External	103 dB(A) (2000/14/EC)
Operator	72 dB(A) (ISO 6396: 2008)

Vibration levels

Hand/arm*	≤ 2.5 m/s ²
Body*	≤ 0.5 m/s ²

*For the risk assessment according to 2002/44/EC, refer to ISO/TR 25398: 2006.

Boom, arm & bucket

Boom cylinders	120 mm × 1,355 mm
Arm cylinder	135 mm × 1,558 mm
Bucket cylinder	120 mm × 1,080 mm
Jib cylinder*	150 mm × 992 mm

* For 2 Piece Boom

Refilling capacities & lubrications

Fuel tank	321 L
Cooling system	23 L
Engine oil	20 L
Travel reduction gear	2 × 4.5 L
Swing reduction gear	1 × 2.7 L
Hydraulic oil tank	140 L tank oil level
	244 L hydraulic system
DEF/Urea tank	33.9 L

Working ranges

Unit: mm

Boom		5.65 m	
Range		Short 2.40 m	Standard 2.94 m
a-	Max. digging reach	9,420	9,900
b-	Max. digging reach at ground level	9,240	9,730
c-	Max. digging depth	6,150	6,690
d-	Max. digging height	9,510	9,730
e-	Max. dumping clearance	6,690	6,920
f-	Min. dumping clearance	2,980	2,440
g-	Max. vertical wall digging depth	5,570	6,100
h-	Min. swing radius	3,570	3,550
i-	Horizontal digging stroke at ground level	4,080	5,270
j-	Digging depth for 2.4m(8') flat bottom	5,950	6,510
Bucket capacity ISO heaped m ³		0.93	0.80

Digging Force (ISO 6015)

Unit: kN

Arm length	Short 2.40 m	Standard 2.94 m
Bucket digging force	143 157*	143 157*
Arm crowding force	121 133*	102 112*

*Power Boost engaged.

Dimensions

Arm length	Short 2.40 m	Standard 2.94 m
A Overall length	9,580	9,500
B Overall height (to top of boom)	3,210	3,040
C Overall width of crawler	2,540	
D Overall height (to top of cab)	3,070	
E Ground clearance of rear end*	1,050	
F Ground clearance*	440	

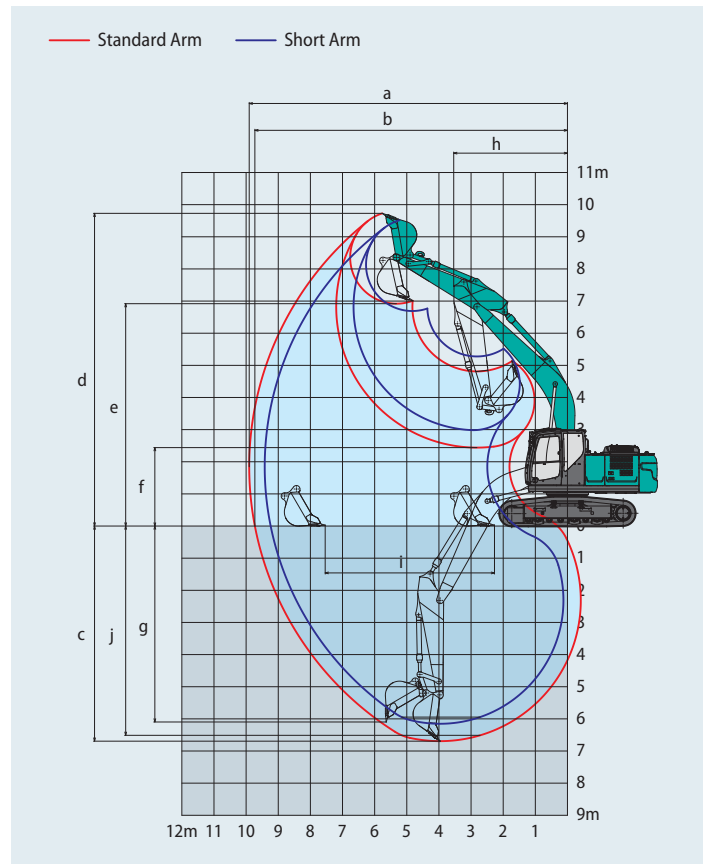

Unit: mm

G	Tail swing radius	2,800
G'	Distance from centre of swing to rear end	2,800
H	Tumbler distance	3,470
I	Overall length of crawler	4,270
J	Track gauge	2,040
K	Shoe width	550
L	Overall width of upperstructure	2,540

*Without including height of shoe

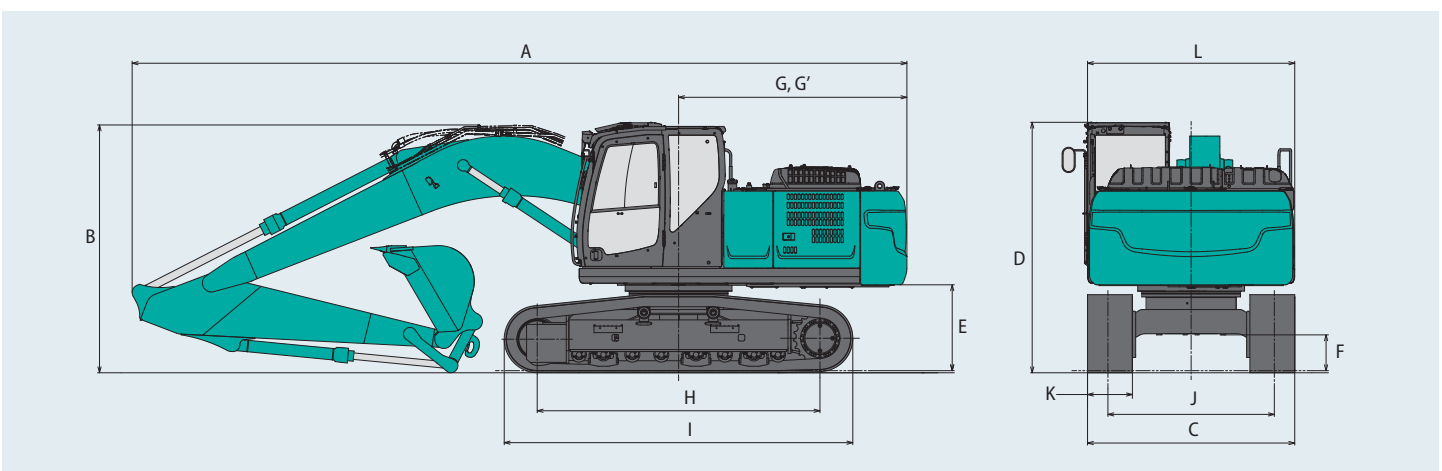

Operating weight & ground pressure

In standard trim, with Standard Boom, 2.94 m arm, and 0.80 m³ ISO heaped bucket

Shaped		Triple grouser shoes (even height)	
Shoe width	mm	550	
Overall width of crawler	mm	2,540	
Ground pressure	kPa	56	
Operating weight	kg	23,600	

Lift capacities

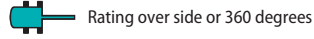
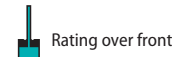
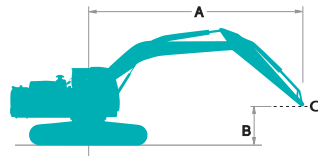

A - Reach from swing centerline to arm top
 B - Arm top height above/below ground
 C - Lift point
 Relief valve setting: 37.8 MPa {385 kgf/cm²}

SK240SN		Boom: 5.65 m Arm: 2.40 m Bucket: without Counterweight: 4,900 kg Shoe: 550 mm (Heavy Lift)										
A \ B		3.0 m		4.5 m		6.0 m		7.5 m		At Max. Reach		
												Radius
7.5 m	kg									*6,370	5,780	5.58 m
6.0 m	kg					*6,570	5,180			*5,800	4,220	6.80 m
4.5 m	kg			*8,380	7,680	*7,030	5,020	5,860	3,560	*5,650	3,540	7.52 m
3.0 m	kg			*10,230	7,100	*7,820	4,780	5,770	3,470	5,330	3,210	7.89 m
1.5 m	kg			*11,680	6,650	7,810	4,550	5,650	3,370	5,180	3,100	7.97 m
G.L.	kg			11,920	6,460	7,650	4,410	5,580	3,310	5,340	3,170	7.75 m
-1.5 m	kg	*11,480	*11,480	*11,550	6,440	7,610	4,380			5,890	3,480	7.22 m
-3.0 m	kg	*13,350	12,220	*10,030	6,560	*7,310	4,480			*6,700	4,240	6.29 m
-4.5 m	kg			*6,360	*6,360					*5,820	*5,820	4.72 m

SK240SN		Boom: 5.65 m Arm: 2.94 m Bucket: without Counterweight: 4,900 kg Shoe: 550 mm (Heavy Lift)												
A \ B		1.5 m		3.0 m		4.5 m		6.0 m		7.5 m		At Max. Reach		
														Radius
7.5 m	kg							*5,330	5,260			*4,300	*4,300	6.26 m
6.0 m	kg							*5,940	5,240			*3,980	3,730	7.36 m
4.5 m	kg							*6,490	5,060	5,890	3,580	*3,890	3,180	8.03 m
3.0 m	kg					*9,450	7,230	*7,360	4,800	5,760	3,460	*3,970	2,910	8.38 m
1.5 m	kg					*11,150	6,700	7,820	4,550	5,620	3,340	*4,200	2,810	8.45 m
G.L.	kg			*6,370	*6,370	11,890	6,420	7,610	4,370	5,520	3,240	*4,640	2,860	8.25 m
-1.5 m	kg	*6,730	*6,730	*11,090	*11,090	*11,770	6,340	7,530	4,300	5,490	3,220	5,260	3,100	7.75 m
-3.0 m	kg	*11,760	*11,760	*14,800	11,950	*10,660	6,410	7,580	4,340			6,250	3,660	6.89 m
-4.5 m	kg			*11,000	*11,000	*8,060	6,650					*6,070	5,100	5.50 m

Notes:

- Do not attempt to lift or hold any load that is greater than these lift capacities at their specified lift point radius and heights. Weight of all accessories must be deducted from the above lift capacities.
- Lift capacities are based on machine standing on level, firm, and uniform ground. User must make allowance for job conditions such as soft or uneven ground, out of level conditions, side loads, sudden stopping of loads, hazardous conditions, experience of personnel, etc.
- Arm top defined as lift point.
- The above lift capacities are in compliance with ISO 10567. They do not exceed 87% of hydraulic lift capacity or 75% of tipping load. Lift capacities marked with an asterisk (*) are limited by hydraulic capacity rather than tipping load.
- Operator should be fully acquainted with the Operator's and Maintenance Instructions before operating this machine. Rules for safe operation of equipment should be adhered to at all times.
- Lift capacities apply to only machine as originally manufactured and normally equipped by KOBELCO CONSTRUCTION MACHINERY CO., LTD.

2 Piece Boom Specifications

SK240^{SN}
SK240SN-11E

Working ranges

Unit: mm

Boom	2 Piece Boom	
Arm	Short 2.40 m	Standard 2.94 m
a- Max. digging reach	9,570	10,070
b- Max. digging reach at ground level	9,390	9,900
c- Max. digging depth	5,890	6,410
d- Max. digging height	10,840	11,240
e- Max. dumping clearance	7,960	8,360
f- Min. dumping clearance	1,520	980
g- Max. vertical wall digging depth	5,070	5,570
h- Min. swing radius	2,780	2,570
i- Horizontal digging stroke at ground level	5,770	6,800
j- Digging depth for 2.4m(8') flat bottom	5,770	6,300
Bucket capacity ISO heaped m ³	0.93	0.80

Digging Force (ISO 6015)

Unit: kN

Arm length	Short 2.40 m	Standard 2.94 m
Bucket digging force	143 157*	143 157*
Arm crowding force	121 133*	102 112*

*Power Boost engaged.

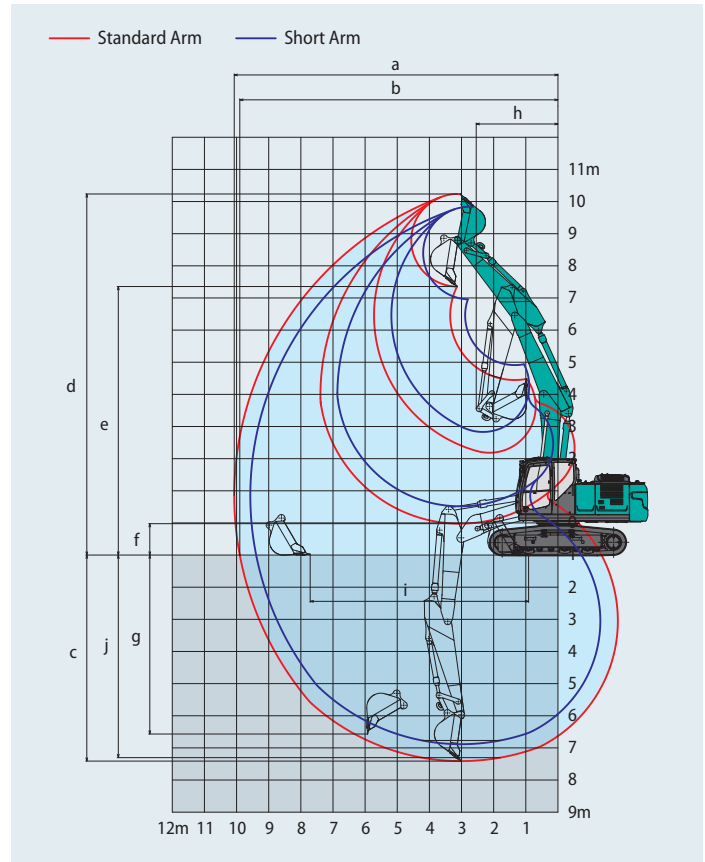

Dimensions

Arm length	Short 2.40 m	Standard 2.94 m
A Overall length	9,660	9,640
B Overall height (to top of boom)	3,030	2,970
C Overall width of crawler	2,540	
D Overall height (to top of cab)	3,070	
E Ground clearance of rear end*	1,050	
F Ground clearance*	440	

Unit: mm

G Tail swing radius	2,800
G' Distance from centre of swing to rear end	2,800
H Tumbler distance	3,470
I Overall length of crawler	4,270
J Track gauge	2,040
K Shoe width	550
L Overall width of upperstructure	2,540

*Without including height of shoe

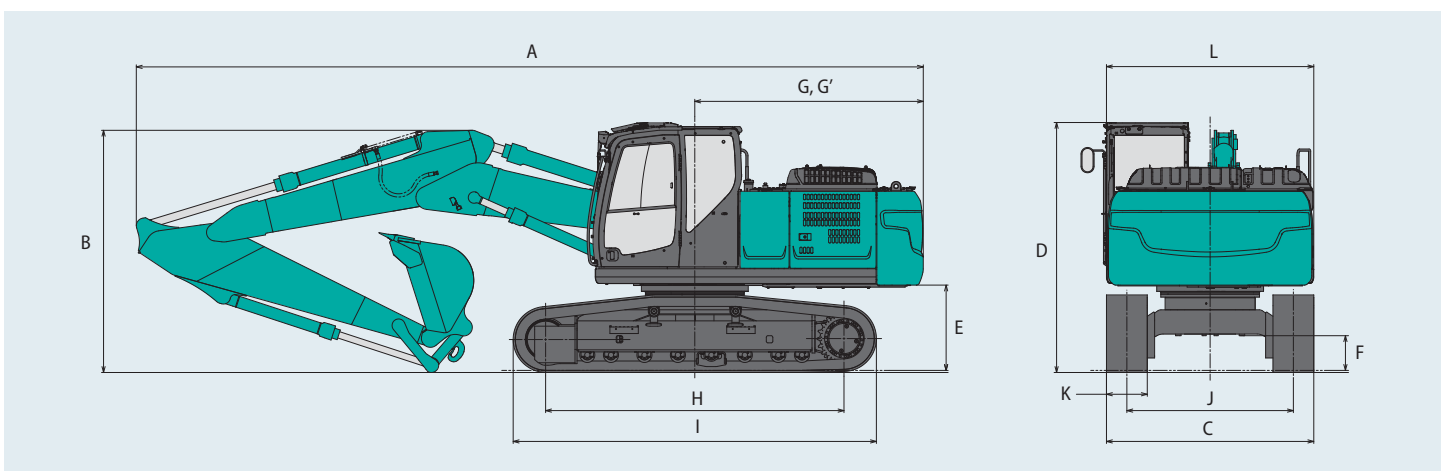

Operating weight & ground pressure

In standard trim, with 2 Piece Boom, 2.94 m arm, and 0.80 m³ ISO heaped bucket.

Shaped	Triple grouser shoes (even height)	
Shoe width	mm	550
Overall width of crawler	mm	2,540
Ground pressure	kPa	59
Operating weight	kg	24,600

Lift capacities

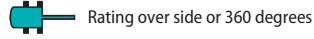
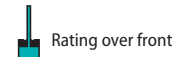
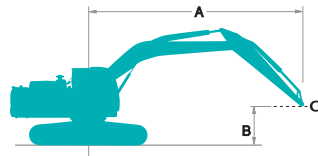

A - Reach from swing centerline to arm top
 B - Arm top height above/below ground
 C - Lift point
 Relief valve setting: 37.8 MPa {385 kgf/cm²}

SK240SN		2 Piece Boom Arm: 2.40 m Bucket: without Counterweight: 4,900 kg Shoe: 550 mm (Heavy Lift)												
A \ B		1.5 m		3.0 m		4.5 m		6.0 m		7.5 m		At Max. Reach		Radius
9.0 m	kg											*7,240	*7,240	3.73 m
7.5 m	kg					*7,980	*7,980					*5,450	5,260	5.80 m
6.0 m	kg					*8,150	8,020	*5,010	*5,010			*4,600	3,840	6.97 m
4.5 m	kg			*12,700	*12,700	*9,050	7,470	*4,260	*4,260	*4,690	3,340	*4,220	3,190	7.68 m
3.0 m	kg			*14,110	12,750	*10,030	6,740	*7,470	4,510	*4,920	3,240	*4,090	2,880	8.05 m
1.5 m	kg			*15,910	11,480	*10,310	6,190	7,570	4,230	*5,250	3,110	*4,150	2,770	8.12 m
G.L.	kg	*22,430	*22,430	*13,860	11,090	*9,550	5,970	*7,240	4,070	5,370	3,040	*4,400	2,840	7.91 m
-1.5 m	kg			*8,560	*8,560	*7,970	5,980	*6,190	4,040			*4,210	3,130	7.39 m
-3.0 m	kg					*5,430	*5,430	*3,980	*3,980			*3,050	*3,050	6.48 m

SK240SN		2 Piece Boom Arm: 2.94 m Bucket: without Counterweight: 4,900 kg Shoe: 550 mm (Heavy Lift)												
A \ B		1.5 m		3.0 m		4.5 m		6.0 m		7.5 m		At Max. Reach		Radius
9.0 m	kg					*5,330	*5,330					*4,460	*4,460	4.74 m
7.5 m	kg					*6,130	*6,130	*5,100	*5,100			*3,650	*3,650	6.49 m
6.0 m	kg					*6,210	*6,210	*4,130	*4,130	*3,700	3,450	*3,340	*3,340	7.55 m
4.5 m	kg			*9,450	*9,450	*8,300	7,690	*6,810	4,910	*4,310	3,410	*3,230	2,880	8.21 m
3.0 m	kg	*28,190	*28,190	*14,620	12,720	*9,640	6,940	*7,250	4,580	*4,270	3,260	*3,250	2,620	8.55 m
1.5 m	kg			*15,880	11,330	*10,260	6,300	*7,530	4,270	*4,590	3,110	*3,400	2,520	8.62 m
G.L.	kg	*18,160	*18,160	*13,120	10,970	*9,920	5,970	7,370	4,060	*5,260	3,000	*3,700	2,560	8.42 m
-1.5 m	kg			*9,060	*9,060	*8,660	5,900	*6,600	3,980	*4,800	2,980	*4,100	2,790	7.93 m
-3.0 m	kg			*7,450	*7,450	*6,500	6,010	*4,930	4,050			*3,270	*3,270	7.10 m
-4.5 m	kg			*10,510	*10,510	*5,880	*5,880					*1,470	*1,470	5.76 m

Notes:

- Do not attempt to lift or hold any load that is greater than these lift capacities at their specified lift point radius and heights. Weight of all accessories must be deducted from the above lift capacities.
- Lift capacities are based on machine standing on level, firm, and uniform ground. User must make allowance for job conditions such as soft or uneven ground, out of level conditions, side loads, sudden stopping of loads, hazardous conditions, experience of personnel, etc.
- Arm top defined as lift point.
- The above lift capacities are in compliance with ISO 10567. They do not exceed 87% of hydraulic lift capacity or 75% of tipping load. Lift capacities marked with an asterisk (*) are limited by hydraulic capacity rather than tipping load.
- Operator should be fully acquainted with the Operator's and Maintenance Instructions before operating this machine. Rules for safe operation of equipment should be adhered to at all times.
- Lift capacities apply to only machine as originally manufactured and normally equipped by KOBELCO CONSTRUCTION MACHINERY CO., LTD.

Standard and Optional Equipment

SK240_{SN}
SK240SN-11E

● = Std ○ = Opt — = N/A

Category	Description	SK240SN-11E	
		Mono Boom / 2 Piece Boom	
Engine	YANMAR 4TN107FTT (EU Stage V compliant)	●	
	Exhaust DOC DPF SCR system	●	
	Alternator 24 V/80 A	●	
	Starter motor 24 V/5 kW	●	
	Batteries 2 x 12 V (130 Ah)	●	
	Fan suction type cooling system	●	
	Auto deceleration function	●	
	Auto idle stop	●	
Hydraulic system	3 work modes H, S, Eco	●	
	Power boost (37.8 MPa (385 kgf/cm ²))	●	
	Heavy lift mode	●	
	Pressure release function	●	
	Independent travel function	●	
	Auto warm up system	●	
	Proportional Hand Control (for E&N&B piping)	●	
	Hydraulic oil VG32	●	
	Hydraulic oil VG46	○	
	Hydraulic oil VG68	○	
Piping	E & N&B piping	●	
	QH piping	●	
Cabin	Air suspension seat with heating	●	
	10 inch colour monitor	●	
	LED door light	●	
	Air-conditioner	●	
	DAB+ radio (FM/AM & AUX & USB & Bluetooth* & hands free telephone)	●	
	Harness for CAB four lights and CAB yellow flasher	●	
	Parallel wiper	●	
	12 V power supply	●	
	Rain visor	○	
	Sun screen	○	
Lights	LED work lights ; 2 on Boom, 1 on upper frame, 2 on rear counterweight	●	
	LED work lights ; 2 on Cab top front	○	
Working equipment	Standard Boom (5.65 m)	●	
	2 Piece Boom	○	
	Standard HD arm (2.94 m) with rock guard	○	
	Short HD arm (2.40 m) with rock ruard	●	
	OHK hook	●	
Counterweight	Standard C/W (TTL 4,900 kg)	●	
Undercarriage	550 mm steel shoe	●	
	Track guide (one per side)	●	
	Additional track guides (two additional per side)	●	
	Reinforced travel motor cover	●	
	HD track link	●	
	Lower frame guard	●	
	Safety	Engine emergency stop switch	●
Pump emergency mode (KPSS release switch)		●	
Emergency accel dial		●	
Emergency manual valve for lowering attachment		●	
Overload alarm		●	
Safety valve for boom & arm cylinder		●	
ROPS compliant cab (ISO 12117-2:2008)		●	
OPG Level II top guard (ISO 10262;1998)		●	
OPG Level II front guard (ISO 10262;1998)		○	
Eagle-eye view camera (Rear, Right, Left)		●	
Seatbelt indicator on display		●	
Extended hand rail		○	
Others		Refueling pump	●
	Harness for engine room light	●	
	RAL color	○	
	KOMEXS	●	

*The air conditioning system on this machine contains fluorinated greenhouse gas HFC-134a (GWP 1430). Quantity of gas 0.8 kg (CO₂ equivalent 1.2 t).
Note: Bluetooth* is a registered trademark of the Bluetooth SIG Inc.

Note: This catalogue may contain attachments and optional equipment that are not available in your area. And it may contain photographs of machines with specifications that differ from those of machines sold in your areas. Please consult your nearest KOBELCO distributor for those items you require.

Specialist equipment is needed to use this machine in demolition work. Before using it please contact your KOBELCO dealer.

Due to our policy of continuous product improvements all designs and specifications are subject to change without advance notice.

Copyright by **KOBELCO CONSTRUCTION MACHINERY CO., LTD.** No part of this catalogue may be reproduced in any manner without notice.

KOBELCO CONSTRUCTION MACHINERY EUROPE B.V.

Veluwezoom 15
1327 AE Almere
The Netherlands
www.kobelco-europe.com

Enquiries To: