

# KOBELCO

SK34SR-7/SK39SR-7

Performance  Design

## SK34SR SK39SR

■ Bucket capacity:

SK34SR 0.09 m<sup>3</sup>

SK39SR 0.11 m<sup>3</sup>

■ Engine power:

18.9 kW / 2,400 min<sup>-1</sup>

■ Operating weight:

SK34SR 3,380 – 3,660 kg

SK39SR 3,780 – 4,060 kg



Complies with the EU Stage V  
exhaust emission regulation

*Built for Perfectionists*

# Performance Design

Mini excavator SK345R/SK395R of KOBELCO has realised a completely new value by harmonising PERFORMANCE and DESIGN.

Performance enhancements offer greater efficiency and productivity along with increased power and speed. Design improvements provide the ultimate in comfort and control.

KOBELCO refuses to compromise, creating machines that meet every challenge.





# UNFORGETTABLE COMFORT

Our pursuit of functional beauty and aesthetic sense produced a new interior design.





### Air suspension seat

A proven Grammer suspension seat is fitted as standard, offering a reclining mechanism, shock absorber, and excellent seating comfort.

### Wrist rests

The enlarged wrist rests keep the operator's forearms in a stable position, reducing fatigue during operation, and allowing stable operation.



### Air conditioner

Additional air vents provide an air flow to envelop the operator's body. In addition, the defrosters placed in front, right and back have also been improved to ensure visibility when the air conditioner is in use.



### LED Illumination

Dials and buttons are now backlit to provide a bright, clear view in any lighting condition.



### Smartphone holder/ USB/AUX port

# FUNCTIONAL WORK ENVIRONMENT

Realisation of the operator's convenience and comfort.



## Colour monitor

A colour display with good readability comes as standard and shows various information such as operating history, maintenance cycle, and fuel and water temperature gauges. It can also be used to adjust the hydraulic oil flow to the attachments.



## Hydraulic flow adjustment (Option)

Rotation or N&B piping flow can be selected from six preset types, or adjusted arbitrarily.



## Engine start password

A password is required when starting the engine for greater security.



## Energy conservation mode

There are 2 working modes: one for maximum power, and ECO-mode for increased fuel economy.



## Auto deceleration

Auto deceleration saves fuel and lowers engine noise by lowering engine speed to idle.



## Maintenance information



## Operation history



### Easy-access cab

The hinged door is adopted to provide large entrance space. Furthermore, the flip-up left console with integrated pilot control lock lever allows for easy entry and exit from the cab.



### Ergonomic lever angles

Operators can move levers horizontally without twisting their wrists, reducing fatigue.

### Proportional hand control for rotation & N&B piping (Option)

Precise proportional controls are integrated into the joystick for ease of operation.



### Slide-open window

The right side window can slide open from the front or the back for increased ventilation and to hear ground workers when required.



**DAB+ radio** (FM/AM & AUX & Bluetooth® & hands-free telephone)



**Speaker**



**12V power outlet**



**Coat hook**



**Cup holder**



**Utility box**



**LED door light**



**Front under glass holder**



# EXPERIENCING A COMPETENT PERFORMANCE

## The new hydraulic system

Compared to previous models, the new hydraulic system is significantly improved, which thereby shortens the digging cycle time remarkably. It attains high performances without reducing the speed even when a heavy load is applied.

By replacing the bucket cylinder,  
the bucket digging force is increased.

## ››› Bucket digging force

Raised by **16%**

(Compared to previous models)

The engine output is increased compared to previous  
models, providing extra power.

## ››› Engine output

**18.9 kW / 2,400 min<sup>-1</sup>**

The newly adopted ECO-mode saves  
even more energy.

## ››› Fuel consumption

Reduced by **25%**

(Compared to H-mode)

## Smoother operation

The new hydraulic system improves levelling performance and makes levelling work easier than with conventional machines when heavier attachments are installed.

## Integrated-Flow Pump System

During the digging operation, depending upon job condition, the machine provides the additional flow to the boom, arm or bucket circuit, from No.3 pump (swing and dozer pump), to increase available input power to those functions.

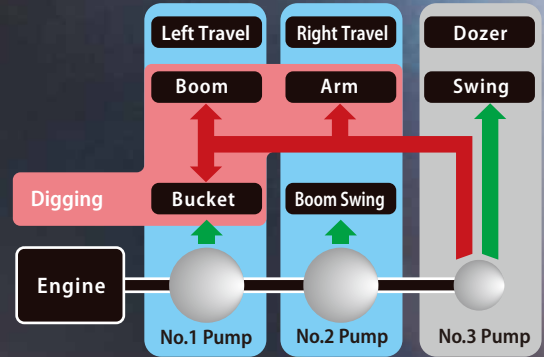

# COMPACT, YET, BIG PERFORMANCE

Min. swing radius  
at boom swing

1,910 mm (SK345R)  
1,930 mm (SK395R)

Figures above show the values for  
cab with standard arm spec.

Tail swing  
radius

775 mm (SK345R)  
850 mm (SK395R)

## Short tail swing

The compact tail swing improves operating  
efficiency in limited space.

Tail overhang

**0 mm (90 mm)**

(without rear view mirror)

Figure in ( ) shows the value with  
additional counterweight.



5,200 mm (SK345R)  
5,350 mm (SK395R)

4,790 mm (SK345R)  
4,870 mm (SK395R)

2,830 mm (SK345R)  
3,050 mm (SK395R)

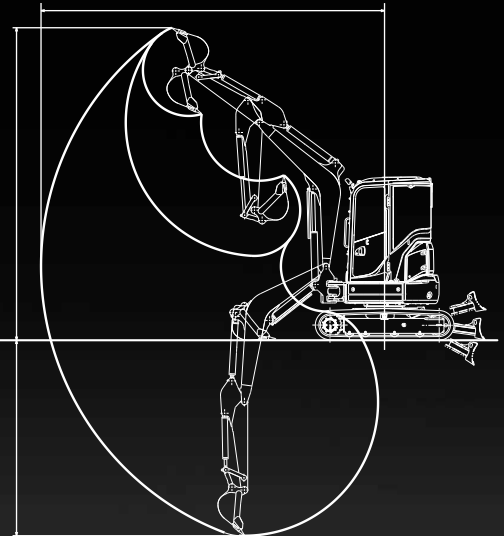

Arm length 1.32 m (SK345R)  
1.37 m (SK395R)

Figures above show the values for cab.

## Wide working range

Long arms are provided as option equipment to  
ensure a wide working range.

# VERSATILITY



## Hydraulic piping for quick hitch (Option)

Various attachments, such as the bucket, can be easily mounted and dismantled without leaving the cab, increasing working speed.



## Dozer lever

The new ergonomic dozer lever has 1st/2nd travel speed select switch integrated into the handle for easier dozer functions.

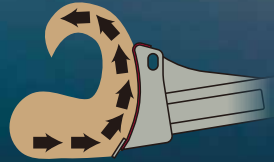

## Angle dozer (Option)

Built-in the same durability as the standard blade, this angle option provides 25 to 25 degrees of left and right angle movement for clearing, grading and back-filling. The angle dozer gives you better control for following changing terrain.

## Dozer-blade shape

KOBELCO's unique blade design solves this problem by forming the earth into an arc that always falls forward. Because this prevents earth from falling behind the blade, only "one pass" is needed.

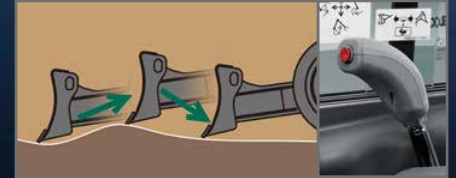

## Floating dozer (Option)

Dozer float is optional to assist in easier leveling work. Floating function can be activated by the switch which is integrated into the dozer control lever.

# RELIABLE CONSTRUCTION

The boom, arm and swing bracket all have large cross-section segments for added attachment strength.

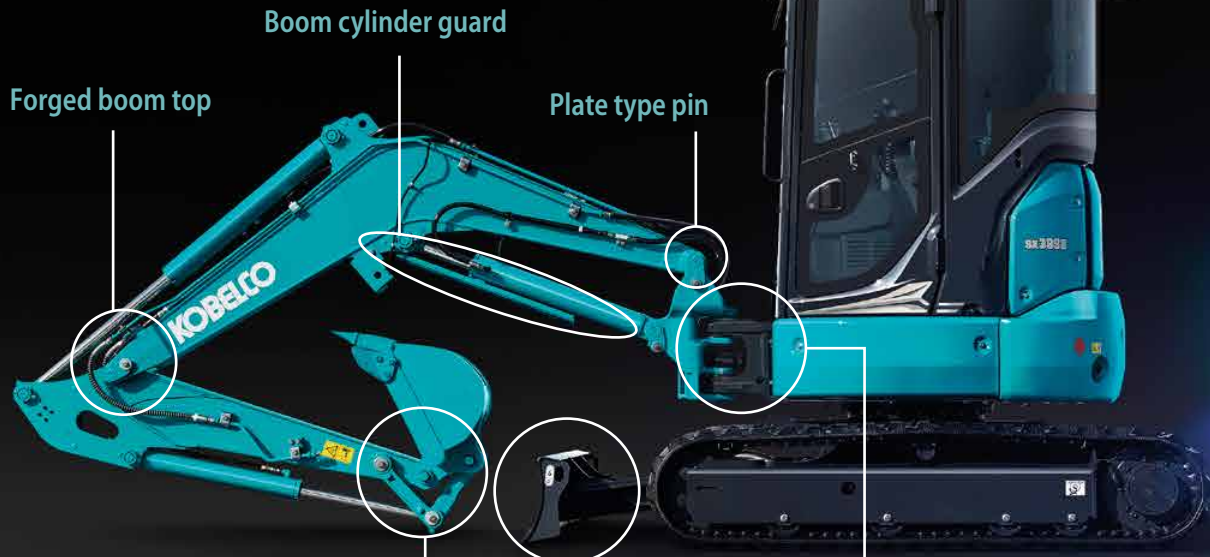

Forged boom top

Boom cylinder guard

Plate type pin

Bucket

Cast-iron idler link provides greater strength.



Dozer

Reinforced dozer supports provide greater strength.



Swing bracket

Large, thick cast-iron swing bracket/front bracket.



Hydraulic hosing

The hydraulic hosing is housed inside the swing bracket for protection.

# NON-STOP OPERATION BY iNDr

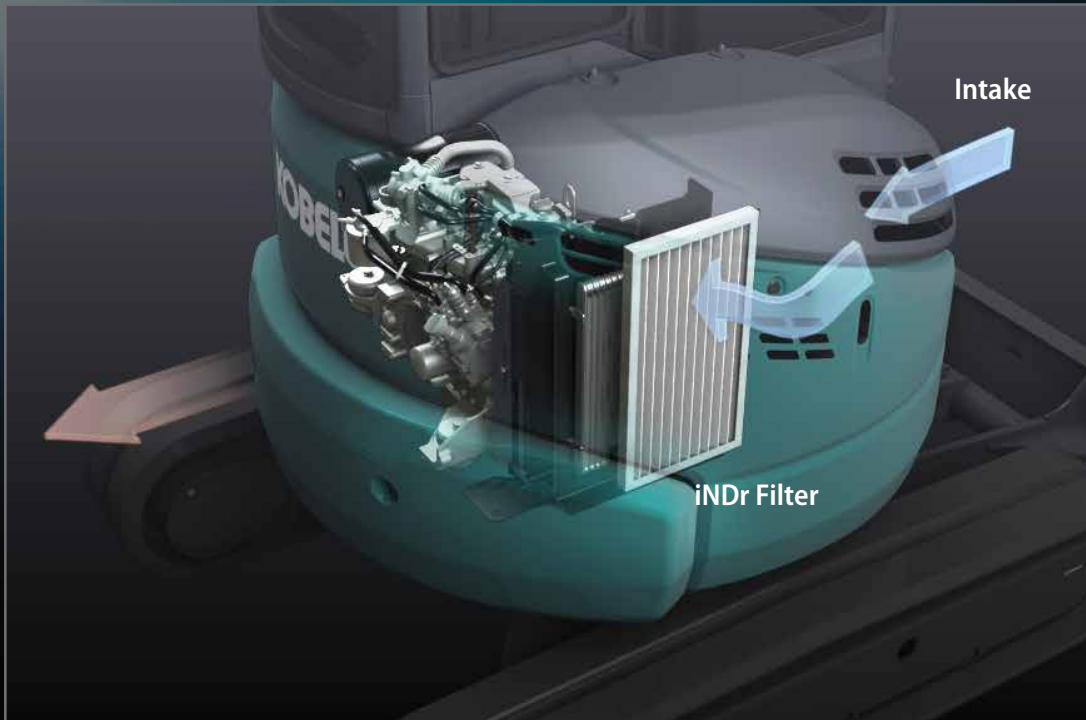

## Ultimate low noise

KOBELCO's exclusive iNDr Cooling System delivers amazingly quiet operation.

Sound Power Level



## iNDr

A high-density mesh filter blocks dust intruding during air intake. This prevents the cooling device and the air cleaner from clogging with dust and maintains their performances. The ridges of the corrugated filter allow the air to pass through, and the grooves collect the dust, which prevents the filter from clogging.

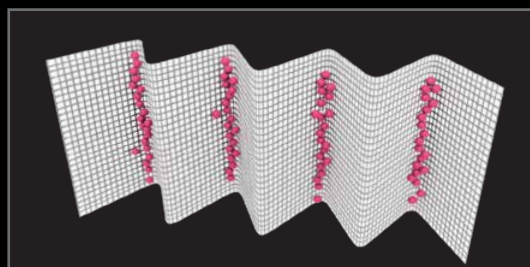

The iNDr filter has a high-density mesh of 30 lines per inch to collect dust.

# EASY MAINTENANCE

Easy daily maintenance that saves the trouble of inspection and cleaning.



## Easy Access to Component Inside the Cab



Hour meter



Cab fresh air intake filter



Cab re-circulation air filter



Operator manual storage pockets

## Easy Access to Cooling Unit



iNDr filter

Laid out for easy access to radiator and cooling system.

## Easy Access to Engine Compartment

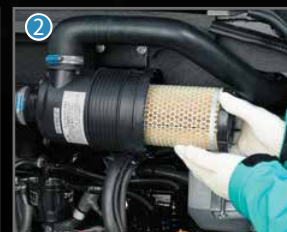

- ① Pre fuel filter with built-in water separator
- ② Air cleaner
- ③ High-grade fuel filter

# OPERATOR SAFETY



## Reliable cab/canopy structure

The high-strength cab/canopy meets ROPS, TOPS and OPG Level 1 (Top guard) standards for greater operator safety.



## LED work light

Changed from halogen light to LED light for more brightness.

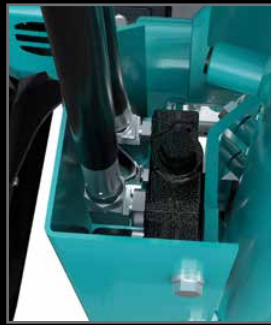

## Safety valve for boom cylinder



## Safety valve for arm cylinder



## Rear wiper (Only cab)



## Good visibility

The wiper mount has been moved to the upper right of the cab support and the skylight opening has been enlarged, improving visibility to the front and above.



## Rear view mirror



## Rear under mirror



## Emergency escape hammer



## Accumulator for emergency attachment lowering

An installed accumulator allows the attachment to be safely lowered to the ground using in-cab controls in the event of an unexpected engine shut-down and class leading smooth operation.

## Standard and Optional Equipment

● = Std ○ = Opt — = N/A

Category	Description	SK34SR-7	SK39SR-7
ENGINE	YANMAR 3TNV88 (EU Stage V compliant)	●	●
	Alternator 12 V /40 A	●	●
	Starter motor 12 V/1.7 kW	●	●
	Battery 1x 12 V (80 Ah)	●	●
	Fan suction type cooling system	●	●
	iNDr system	●	●
	Auto deceleration function	●	●
	Accelerator dial	●	●
	ECO-mode	●	●
	Engine start password	●	●
HYDRAULIC SYSTEM	Integrated-Flow Pump System	●	●
	Foot control (for N&B piping)	●	●
	PHC (for N&B piping) with hydraulic flow adjustment	○	○
	PHC (for Rotation &N&B piping) with hydraulic flow adjustment	○	○
	Hydraulic oil VG32	●	●
	Hydraulic oil VG46	○	○
PIPING	Hydraulic oil VG68	○	○
	N&B piping	●	●
	Rotation &N&B piping	○	○
CABIN	QH piping	○	○
	Air suspension seat (Canopy: PVC / Cab: fabric)	●	●
	Headrest*	●	●
	Retractable seatbelt	●	●
	Multi-function color display	●	●
	LED door light*	●	●
	Air-conditioner*	●	●
	DAB+ radio (FM/AM & AUX & USB & Bluetooth* & hands free telephone)*	●	●
	Cup holder	●	●
	Coat hook*	●	●
	Smart phone holder*	●	●
	USB/AUX port*	●	●
	12V power outlet	●	●
Harness for cab beacon light*	●	●	
Sun screen*	●	●	
LIGHTS	LED work lights ; 1 on boom, 1 on cab top front / canopy front	●	●
WORKING EQUIPMENT	Standard Boom (2.36 m)	●	—
	Standard Boom (2.47 m)	—	●
	Standard Arm (1.32 m)	●	—
	Standard Arm (1.37 m)	—	●
	Long Arm (1.62 m)	○	—
	Long Arm (1.67 m)	—	○
COUNTERWEIGHT	Standard C/W	●	●
	Additional C/W (+250 kg)	○	○
UNDERCARRIAGE	300mm rubber shoe	●	●
	300mm steel shoe	○	○
	Dozer blade (1,550 mm)	●	—
	Dozer blade (1,700 mm)	—	●
	Floating dozer	○	○
SAFETY EQUIPMENT	Angle dozer	○	○
	Cab (ROPS(ISO 3471 : 2008) / TOPS(ISO 12117 : 1997) / OPG(ISO 10262 : 1998)	●	●
	Canopy (ROPS(ISO 3471 : 2008) / TOPS(ISO 12117 : 1997) / OPG(ISO 10262 : 1998)	○	○
	Front guard	○	○
	Top guard*	○	○
	Safety valve for Boom & Arm cylinder + bucket link with lifting hook + overload alarm	●	●
	Rear view mirror (left)	●	●
	Rear under mirror (right rear)	●	●
	Travel alarm	○	○
	Rear wiper*	●	●
OTHERS	Emergency escape hammer	●	●
	Boom cylinder rod guard	●	●
	Arm & bucket cylinder rod guard	○	○
	RAL colour	○	○
	KOMEXS	○	○

\* Only for Cab

Note: The air conditioning system on this machine contains fluorinated greenhouse gas HFC-134a (GWP 1430). Quantity of gas 0.6 kg (CO<sub>2</sub> equivalent 0.9 t).

Bluetooth\* is a registered trademark of the Bluetooth SIG Inc.

# Specifications

## Engine

Model	YANMAR 3TNV88
Type	Four-cycle, water-cooled, direct injection diesel engine, complies with EU Stage V exhaust emission regulation
No. of cylinders	3
Bore and stroke	88 mm x 90 mm
Displacement	1,642 ml
Rated power output	17.9 kW / 2,400 min <sup>-1</sup> (ISO 9249 : with fan)
	18.9 kW / 2,400 min <sup>-1</sup> (ISO 14396: without fan)
Max. torque	88.0 N·m / 1,440 min <sup>-1</sup> (ISO 14396: without fan)

## Hydraulic system

Pump			
Type	Two variable displacement axial piston pumps + one gear pump + pilot pump		
Max. discharge flow	2 x 38.4 L/min	1 x 19.2 L/min	1 x 10.8 L/min
Relief valve setting			
Boom, arm and bucket	23.0 MPa {235 kgf/cm <sup>2</sup> }		
Travel circuit	23.0 MPa {235 kgf/cm <sup>2</sup> }		
Swing circuit	20.0 MPa {204 kgf/cm <sup>2</sup> }		
Control circuit	3.5 MPa {36 kgf/cm <sup>2</sup> }		
Pilot control pump	Gear type		
Main control valve	10-spool valve		
Oil cooler	Air cooled type		

## Swing system

Swing motor	One fixed displacement piston motor
Brake	Hydraulic; locking automatically when the swing control lever is in the neutral position
Parking brake	Wet multiple plate
Swing speed	8.2 min <sup>-1</sup>
Swing torque	7.0 kN·m
Maximum swing gradient (Loaded)*	28 % {16 °}

\*Value for the least favourable specification

## Travel system

Travel motors	Two variable displacement piston motors	
Travel brakes	Hydraulic brake	
Parking brakes	Wet multiple plate	
Travel shoes	88 each side	
Travel speed	4.4/2.5 km/h (rubber shoe)	
	4.3/2.4 km/h (steel shoe)	
Drawbar pulling force	SK345R	38.2 kN (Cab) / 38.3 kN (Canopy)
	SK395R	38.0 kN (Cab) / 38.1 kN (Canopy)
Gradeability	58% (30°)	

## Cab & control

Cab	
All-weather, insulated floor mat.	
Control	
Two hand levers and two foot pedals for travel	
Two hand levers for excavating and swing	
Electric rotary-type engine throttle	
Foot control (for boom swing)	
Foot control (for N&B piping)	
Dozer lever	
Noise levels	
External	93 dB(A) (2000/14/EC)
Operator	81 dB(A) (ISO 6396)

## Boom, arm & bucket

Model	SK345R		SK395R	
	Cab	Canopy	Cab	Canopy
Boom cylinders	80 mm x 574 mm	80 mm x 592 mm	85 mm x 582 mm	85 mm x 588 mm
Arm cylinder	75 mm x 627 mm		80 mm x 677 mm	
Bucket cylinder	70 mm x 507 mm			
Swing cylinder	80 mm x 477 mm			

bore x stroke

## Dozer blade

Dozer cylinder	90 mm x 180 mm
----------------	----------------

bore x stroke

## Refilling capacities & lubrications

Fuel tank	42 L
Cooling system	3.8 L
Engine oil	6.7 L
Travel reduction gear	2 x 0.6 L
Hydraulic oil tank	20.4 L tank oil level
	44.8 L hydraulic system

## Working ranges

Unit: mm

Model	SK34SR				SK39SR			
	Cab		Canopy		Cab		Canopy	
Arm length	1.32 m		1.62 m		1.37 m		1.67 m	
a- Max. digging reach	5,200		5,490		5,350		5,640	
b- Max. digging reach at ground level	5,040		5,340		5,200		5,490	
c- Max. digging depth	2,830	2,780	3,130	3,080	3,050	2,970	3,350	3,270
d- Max. digging height	4,790	5,050	5,000	5,280	4,870	5,040	5,050	5,240
e- Max. dumping clearance	3,410	3,640	3,600	3,860	3,490	3,650	3,670	3,850
f- Min. dumping clearance	1,290	1,430	995	1,140	1,310	1,400	1,010	1,100
g- Max. vertical wall digging depth	2,370		2,860		2,470		2,760	
h- Min. swing radius at boom straight	2,300	2,190	2,340	2,270	2,320	2,180	2,330	2,220
h'-Min. swing radius at boom swing	1,910	1,810	1,950	1,880	1,930	1,810	1,940	1,840
i- Horizontal digging stroke at ground level	2,230		2,640		2,400		2,860	
j- Digging depth for 2.4 m (8') flat bottom	2,360	2,310	2,720	2,670	2,580	2,510	2,930	2,860
k- Dozer blade (height/depth) (mm)	470/390							

\*Figures in the above tables show the value with 0.09–0.11 m<sup>3</sup> bucket. Regarding bucket capacity, 0.09 m<sup>3</sup> in this catalogue is equivalent to 0.08 m<sup>3</sup> in ISO07451 and 0.11 m<sup>3</sup> in this catalogue is equivalent to 0.10 m<sup>3</sup> in ISO07451.

## Digging force (ISO 6015)

Unit: kN

Model	SK34SR		SK39SR	
Arm length	1.32 m		1.62 m	
Bucket digging force	32.2			
Arm crowding force	19.1	16.5	22.4	19.5

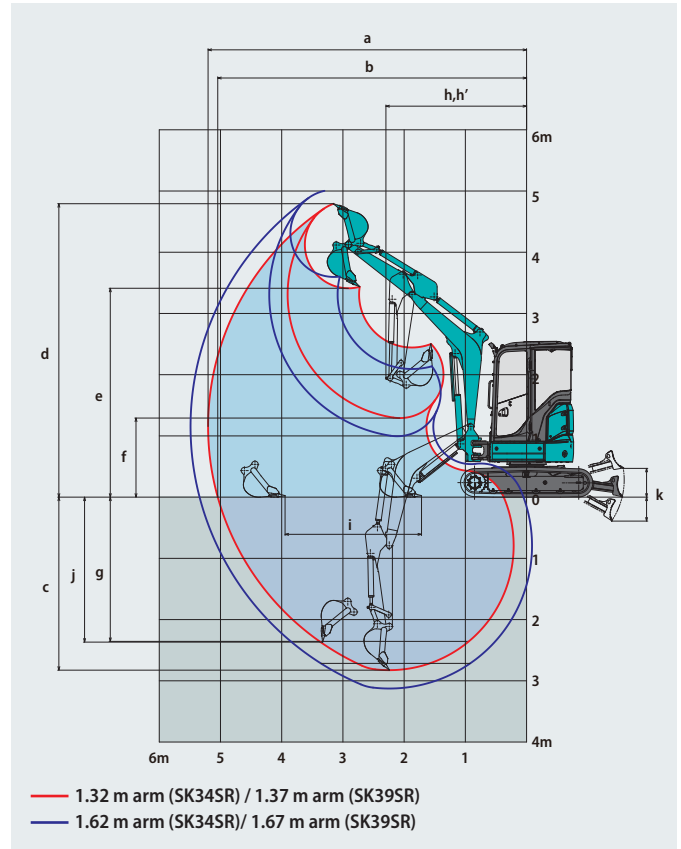

## Dimensions

Unit: mm

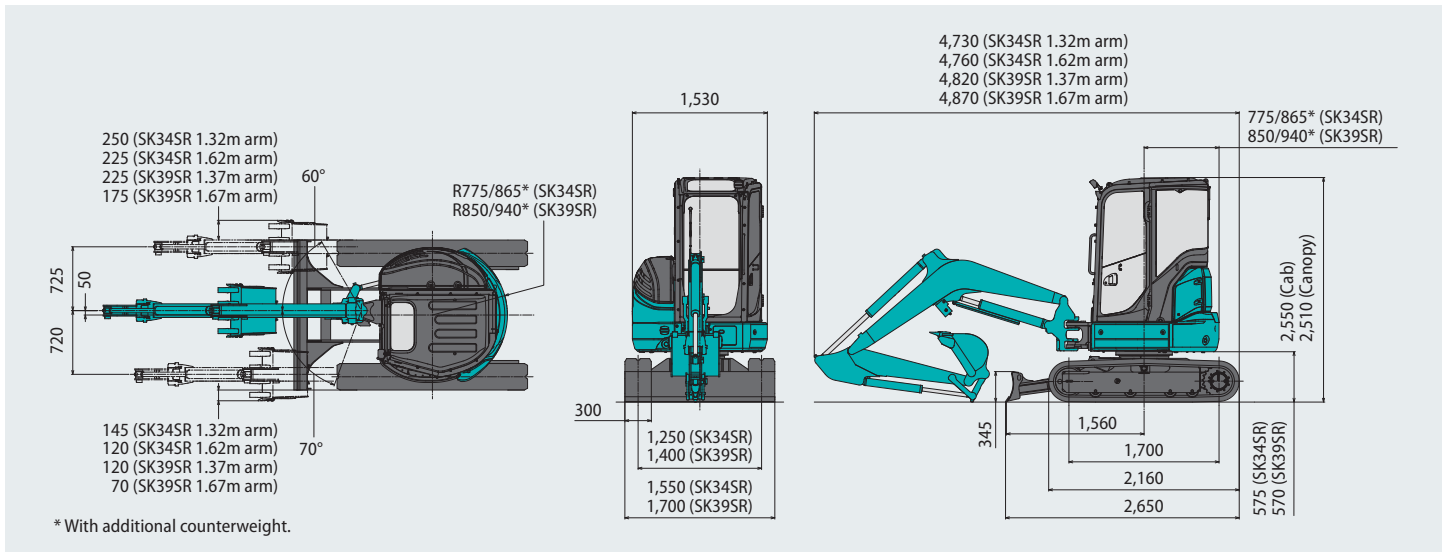

\* With additional counterweight.

## Operating weight & ground pressure

In standard trim, with standard boom, standard arm, and 0.09 m<sup>3</sup> (80 kg) – 0.11 m<sup>3</sup> (80 kg) bucket.

Model	SK34SR				SK39SR			
	Cab		Canopy		Cab		Canopy	
Shaped	Steel shoe	Rubber shoe	Steel shoe	Rubber shoe	Steel shoe	Rubber shoe	Steel shoe	Rubber shoe
Shoe width	300							
Overall width of crawler	1,550				1,700			
Ground pressure	32.1	31.1	30.7	29.7	35.5	34.6	34.1	33.2
Operating weight	3,660	3,550	3,500	3,380	4,060	3,940	3,890	3,780

\* Regarding bucket capacity, 0.09 m<sup>3</sup> in this catalogue is equivalent to 0.08 m<sup>3</sup> in ISO 07451 and 0.11 m<sup>3</sup> in this catalogue is equivalent to 0.10 m<sup>3</sup> in ISO 07451.

# Lift capacities

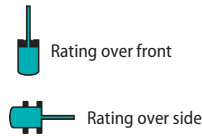
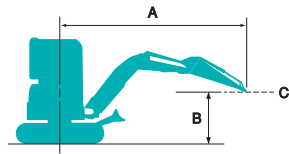

A: Reach from swing centreline to arm top  
 B: Arm top height above/below ground  
 C: Lift point  
 Bucket: Without  
 Dozer: Blade up  
 Relief valve setting: 23.0 MPa

SK34SR Canopy		Arm: 1.32 m		Standard counterweight		Rubber shoe: 300 mm						
B	A	1.0m		2.0m		3.0m		4.0m		At max. reach		
		Rating over front	Rating over side	Rating over front	Rating over side	Rating over front	Rating over side	Rating over front	Rating over side	Rating over front	Rating over side	Radius
4.0m	kg					770	600			730	570	3.08m
3.0m	kg					*750	610			470	370	3.98m
2.0m	kg					730	570	460	360	390	300	4.39m
1.0m	kg					670	510	430	340	360	280	4.49m
G.L.	kg			1,230	890	640	480	420	320	380	290	4.30m
-1.0m	kg	*2,050	*2,050	1,250	900	640	480			460	360	3.77m
-2.0m	kg			*970	960					*640	*640	2.60m

SK34SR Cab		Arm: 1.32 m		Standard counterweight		Rubber shoe: 300 mm								
B	A	1.0m		2.0m		3.0m		4.0m		At max. reach				
		Rating over front	Rating over side	Rating over front	Rating over side	Rating over front	Rating over side	Rating over front	Rating over side	Rating over front	Rating over side	Radius		
4.0m	kg							810	640			770	610	3.08m
3.0m	kg											500	390	3.98m
2.0m	kg							770	600	490	380	420	320	4.39m
1.0m	kg							720	550	470	360	390	300	4.49m
G.L.	kg			1,320	950	680	520	450	350	410	320	4.30m		
-1.0m	kg	*2,050	*2,050	1,340	970	690	520			500	380	3.77m		
-2.0m	kg			*970	*970					*640	*640	2.60m		

SK34SR Canopy		Arm: 1.62 m		Standard counterweight		Rubber shoe: 300 mm						
B	A	1.0m		2.0m		3.0m		4.0m		At max. reach		
		Rating over front	Rating over side	Rating over front	Rating over side	Rating over front	Rating over side	Rating over front	Rating over side	Rating over front	Rating over side	Radius
4.0m	kg									580	460	3.52m
3.0m	kg							470	370	410	320	4.31m
2.0m	kg					740	570	460	350	340	270	4.68m
1.0m	kg					670	510	430	330	320	250	4.77m
G.L.	kg			1,210	860	630	470	410	310	340	260	4.60m
-1.0m	kg	*1,650	*1,650	1,220	870	620	470	410	310	400	300	4.12m
-2.0m	kg			1,270	920	650	490			610	460	3.14m

SK34SR Cab		Arm: 1.62 m		Standard counterweight		Rubber shoe: 300 mm						
B	A	1.0m		2.0m		3.0m		4.0m		At max. reach		
		Rating over front	Rating over side	Rating over front	Rating over side	Rating over front	Rating over side	Rating over front	Rating over side	Rating over front	Rating over side	Radius
4.0m	kg									620	490	3.52m
3.0m	kg									500	390	4.31m
2.0m	kg					780	610	490	380	370	290	4.68m
1.0m	kg					720	550	460	360	350	270	4.77m
G.L.	kg			1,300	930	680	510	440	340	360	280	4.60m
-1.0m	kg	*1,650	*1,650	1,310	940	670	500	440	340	430	330	4.12m
-2.0m	kg			1,360	980	700	530			650	500	3.14m

SK34SR Canopy		Arm: 1.32 m		Additional counterweight (+250 kg)		Rubber shoe: 300 mm						
B	A	1.0m		2.0m		3.0m		4.0m		At max. reach		
		Rating over front	Rating over side	Rating over front	Rating over side	Rating over front	Rating over side	Rating over front	Rating over side	Rating over front	Rating over side	Radius
4.0m	kg					*820	730			*840	690	3.08m
3.0m	kg					*750	730			570	460	3.98m
2.0m	kg					880	690	560	440	480	380	4.39m
1.0m	kg					820	640	540	420	450	360	4.49m
G.L.	kg			1,510	1,110	790	610	520	410	470	370	4.30m
-1.0m	kg	*2,050	*2,050	1,530	1,120	790	610			570	450	3.77m
-2.0m	kg			*970	*970					*640	*640	2.61m

SK34SR Cab		Arm: 1.32 m		Additional counterweight (+250 kg)		Rubber shoe: 300 mm						
B	A	1.0m		2.0m		3.0m		4.0m		At max. reach		
		Rating over front	Rating over side	Rating over front	Rating over side	Rating over front	Rating over side	Rating over front	Rating over side	Rating over front	Rating over side	Radius
4.0m	kg					*820	760			*840	730	3.08m
3.0m	kg									640	480	3.98m
2.0m	kg					*970	730	630	470	540	400	4.39m
1.0m	kg					920	670	610	450	510	380	4.49m
G.L.	kg			1,540	1,170	890	640	590	440	540	400	4.30m
-1.0m	kg	*2,050	*2,050	1,720	1,190	890	640			650	480	3.77m
-2.0m	kg			*970	*970					*640	*640	2.61m

SK34SR Canopy		Arm: 1.62 m		Additional counterweight (+250 kg)		Rubber shoe: 300 mm						
B	A	1.0m		2.0m		3.0m		4.0m		At max. reach		
		Rating over front	Rating over side	Rating over front	Rating over side	Rating over front	Rating over side	Rating over front	Rating over side	Rating over front	Rating over side	Radius
4.0m	kg									700	560	3.53m
3.0m	kg							570	460	500	400	4.31m
2.0m	kg					*840	700	560	440	430	340	4.68m
1.0m	kg					820	640	530	420	400	320	4.77m
G.L.	kg			1,490	1,080	780	600	510	400	420	330	4.60m
-1.0m	kg	*1,650	*1,650	1,500	1,090	770	590	510	400	490	390	4.12m
-2.0m	kg			*1,430	1,140	*790	620			*690	580	3.15m

SK34SR Cab		Arm: 1.62 m		Additional counterweight (+250 kg)		Rubber shoe: 300 mm						
B	A	1.0m		2.0m		3.0m		4.0m		At max. reach		
		Rating over front	Rating over side	Rating over front	Rating over side	Rating over front	Rating over side	Rating over front	Rating over side	Rating over front	Rating over side	Radius
4.0m	kg									*720	590	3.53m
3.0m	kg							600	480	530	420	4.31m
2.0m	kg					*840	730	590	470	450	360	4.68m
1.0m	kg					870	670	560	440	430	340	4.77m
G.L.	kg			1,520	1,150	820	630	540	420	450	350	4.60m
-1.0m	kg	*1,650	*1,650	1,580	1,160	820	630	540	420	520	410	4.12m
-2.0m	kg			*1,430	1,200	*790	650			*690	610	3.15m

SK39SR Canopy		Arm: 1.37 m		Standard counterweight		Rubber shoe: 300 mm						
B	A	1.0m		2.0m		3.0m		4.0m		At max. reach		
											Radius	
4.0m	kg									790	740	3.32m
3.0m	kg							580	550	540	510	4.15m
2.0m	kg					890	830	570	530	460	430	4.54m
1.0m	kg					820	760	540	510	430	410	4.64m
G.L.	kg			1,520	1,360	790	730	520	490	450	420	4.46m
-1.0m	kg	*2,290	*2,290	1,540	1,380	790	730			540	500	3.96m
-2.0m	kg			*1,540	1,440					870	810	2.90m

SK39SR Cab		Arm: 1.37 m		Standard counterweight		Rubber shoe: 300 mm						
B	A	1.0m		2.0m		3.0m		4.0m		At max. reach		
											Radius	
4.0m	kg									*830	770	3.32m
3.0m	kg									610	570	4.15m
2.0m	kg					930	860	590	560	480	450	4.54m
1.0m	kg					870	800	570	530	460	430	4.64m
G.L.	kg			1,600	1,430	830	770	550	510	480	450	4.46m
-1.0m	kg	*2,290	*2,290	1,620	1,450	830	770			570	530	3.96m
-2.0m	kg			*1,540	1,500					*890	840	2.90m

SK39SR Canopy		Arm: 1.67 m		Standard counterweight		Rubber shoe: 300 mm						
B	A	1.0m		2.0m		3.0m		4.0m		At max. reach		
											Radius	
4.0m	kg									650	610	3.74m
3.0m	kg							590	550	480	450	4.48m
2.0m	kg					*880	840	570	530	410	390	4.84m
1.0m	kg					830	770	540	500	390	370	4.92m
G.L.	kg			1,500	1,340	780	720	520	480	400	380	4.76m
-1.0m	kg	*1,870	*1,870	1,510	1,350	770	710	510	480	470	440	4.30m
-2.0m	kg			1,550	1,400	800	740			670	620	3.40m

SK39SR Cab		Arm: 1.67 m		Standard counterweight		Rubber shoe: 300 mm						
B	A	1.0m		2.0m		3.0m		4.0m		At max. reach		
											Radius	
4.0m	kg									680	640	3.74m
3.0m	kg									620	580	4.48m
2.0m	kg					*880	880	600	560	440	410	4.84m
1.0m	kg					870	800	570	530	410	390	4.92m
G.L.	kg			1,570	1,410	820	760	550	510	430	400	4.76m
-1.0m	kg	*1,870	*1,870	1,580	1,420	810	750	540	500	490	460	4.30m
-2.0m	kg	*3,070	*3,070	1,630	1,460	840	770			710	650	3.40m

SK39SR Canopy		Arm: 1.37 m		Additional counterweight (+250 kg)		Rubber shoe: 300 mm						
B	A	1.0m		2.0m		3.0m		4.0m		At max. reach		
											Radius	
4.0m	kg									*830	*830	3.32m
3.0m	kg							680	640	640	600	4.15m
2.0m	kg					*1,030	960	670	620	550	510	4.54m
1.0m	kg					970	900	640	600	520	490	4.64m
G.L.	kg			*1,650	1,610	940	870	630	580	540	510	4.46m
-1.0m	kg	*2,290	*2,290	1,820	1,630	940	870			640	600	3.96m
-2.0m	kg			*1,540	*1,540					*890	*890	2.90m

SK39SR Cab		Arm: 1.37 m		Additional counterweight (+250 kg)		Rubber shoe: 300 mm						
B	A	1.0m		2.0m		3.0m		4.0m		At max. reach		
											Radius	
4.0m	kg									*830	*830	3.32m
3.0m	kg									710	660	4.15m
2.0m	kg					*1,030	1,000	700	650	570	530	4.54m
1.0m	kg					1,010	940	670	620	540	510	4.64m
G.L.	kg			*1,650	*1,650	980	900	650	610	570	530	4.46m
-1.0m	kg	*2,290	*2,290	1,890	1,690	980	900			670	620	3.96m
-2.0m	kg			*1,540	*1,540					*890	*890	2.90m

SK39SR Canopy		Arm: 1.67 m		Additional counterweight (+250 kg)		Rubber shoe: 300 mm						
B	A	1.0m		2.0m		3.0m		4.0m		At max. reach		
											Radius	
4.0m	kg									*730	710	3.74m
3.0m	kg							*680	650	570	530	4.48m
2.0m	kg					*880	*880	670	630	490	460	4.84m
1.0m	kg					980	910	640	600	470	440	4.92m
G.L.	kg			*1,650	1,590	930	860	620	580	490	450	4.76m
-1.0m	kg	*1,870	*1,870	1,780	1,600	920	850	610	570	560	520	4.30m
-2.0m	kg			1,830	1,640	950	870			800	740	3.40m

SK39SR Cab		Arm: 1.67 m		Additional counterweight (+250 kg)		Rubber shoe: 300 mm						
B	A	1.0m		2.0m		3.0m		4.0m		At max. reach		
											Radius	
4.0m	kg									*730	*730	3.74m
3.0m	kg							*680	670	590	550	4.48m
2.0m	kg					*880	*880	700	650	520	480	4.84m
1.0m	kg					1,020	940	670	620	490	460	4.92m
G.L.	kg			*1,650	*1,650	970	890	650	600	510	470	4.76m
-1.0m	kg	*1,870	*1,870	1,860	1,660	960	890	640	600	580	540	4.30m
-2.0m	kg	*3,070	*3,070	1,910	1,710	990	910			830	770	3.40m

**Notes:**

- Do not attempt to lift or hold any load that is greater than these lift capacities at their specified lift point radius and heights. Weight of all accessories must be deducted from the above lift capacities.
- Lift capacities are based on machine standing on level, firm, and uniform ground. User must make allowance for job conditions such as soft or uneven ground, out of level conditions, side loads, sudden stopping of loads, hazardous conditions, experience of personnel, etc.
- Arm top defined as lift point.
- The above lift capacities are in compliance with ISO 10567. They do not exceed 87% of hydraulic lift capacity or 75% of tipping load. Lift capacities marked with an asterisk(\*) are limited by hydraulic capacity rather than tipping load.
- Operator should be fully acquainted with the Operator's and Maintenance Instructions before operating this machine. Rules for safe operation of equipment should be adhered to at all times.
- Lift capacities apply to only machine as originally manufactured and normally equipped by KOBELCO CONSTRUCTION MACHINERY CO., LTD.



## Total Support for Machines with Network Speed and Accuracy Option

KOMEXS is a telematics system for receiving machine information. Manage your machines anywhere in the world using the Internet. Location, workload and diagnostic data aid business operations.

### Direct Access to Operational Status

#### Location Data

Accurate location data can be obtained even from sites where communications are difficult.

#### Fuel Consumption Data

Data on fuel consumption and idling times can be used to indicate improvements in fuel consumption.

#### Operating Hours

A comparison of operating times of machines at multiple locations shows which locations are busier and more profitable. Operating hours on site can be accurately recorded, for running time calculations needed for rental machines, etc.

#### Graph of Work Content

The graph shows how working hours are divided among different operating categories.



### Maintenance Data and Warning Alerts

#### Machine Maintenance Data

Provides maintenance status of separate machines operating at multiple sites. Maintenance data is also relayed to KOBELCO service personnel, for more efficient planning of periodic servicing.

#### Security System

##### Engine Start Alarm

Sends a notification if the engine is started outside of pre-defined hours.

##### Area Alarm

Sends a notification if the machine leaves a pre-defined area.

Note: This catalogue may contain attachments and optional equipment that are not available in your area. And it may contain photographs of machines with specifications that differ from those of machines sold in your areas. Please consult your nearest KOBELCO distributor for those items you require. Specialist equipment is needed to use this machine in demolition work. Before using it please contact your KOBELCO dealer. Due to our policy of continuous product improvements all designs and specifications are subject to change without advance notice. Copyright by **KOBELCO CONSTRUCTION MACHINERY CO., LTD.** No part of this catalogue may be reproduced in any manner without notice.

## KOBELCO CONSTRUCTION MACHINERY EUROPE B.V.

[www.kobelco-europe.com](http://www.kobelco-europe.com)



Enquiries To: